

Process Intensification: Transforming Chemical Engineering

ANDRZEJ I. STANKIEWICZ,
DSM RESEARCH/DELFT UNIVERSITY
OF TECHNOLOGY
JACOB A. MOULIJN,
DELFT UNIVERSITY OF TECHNOLOGY

Emerging equipment, processing techniques, and operational methods promise spectacular improvements in process plants, markedly shrinking their size and dramatically boosting their efficiency. These developments may result in the extinction of some traditional types of equipment, if not whole unit operations.

Today, we are witnessing important new developments that go beyond “traditional” chemical engineering. Engineers at many universities and industrial research centers are working on novel equipment and techniques that potentially could transform our concept of chemical plants and lead to compact, safe, energy-efficient, and environment-friendly sustainable processes. These developments share a common focus on “process intensification” — an approach that has been around for quite some time but has truly emerged only in the past few years as a special and interesting discipline of chemical engineering.

In this article, we take a closer look at process intensification. We define what it involves, discuss its dimensions and structure, and review recent developments in process-intensifying devices and methods.

What is process intensification?

One of the woodcuts in the famous 16th century book by Georgius Agricola (*1*) illustrates the process of retrieving gold from gold ore (Figure 1). The resemblance between some of the devices shown in the picture (for instance, the stirred vessels *O* and the stirrers *S*) and the basic equipment of today’s chemical process industries (CPI) is striking. Indeed, Agricola’s drawing shows that process intensi-

fication, no matter how we define it, does not seem to have had much impact in the field of stirring technology over the last four centuries, or perhaps even longer. But, what actually is process intensification?

In 1995, while opening the 1st International Conference on Process Intensification in the Chemical Industry, Ramshaw, one of the pioneers in the field, defined process intensification as a strategy for making dramatic reductions in the size of a chemical plant so as to reach a given production objective (*2*). These reductions can come from shrinking the size of individual pieces of equipment and also from cutting the number of unit operations or apparatuses involved. In any case, the degree of reduction must be significant; how significant remains a matter of discussion. Ramshaw speaks about volume reduction on the order of 100 or more, which is quite a challenging number. In our view, a decrease by a factor of two already bears all attributes of a drastic step change and, therefore, should be considered as process intensification.

On the other hand, Ramshaw’s definition is quite narrow, describing process intensification exclusively in terms of the reduction in plant or equipment size. In fact, this is merely one of several possible desired effects. Clearly, a dramatic increase in the production ca-



■ Figure 1. 16th century technology for retrieving gold from ore (1).

capacity within a given equipment volume, a step decrease in energy consumption per ton of product, or even a marked cut in wastes or byproducts formation also qualify as process intensification.

Not surprisingly, process intensification, being driven by the need for breakthrough changes in operations, focuses mainly on novel methods and equipment. But, it also encompasses

certain established technologies and hardware. Usually, these have been applied on a limited scale (at least in comparison with their potential) and have not yet generally been recognized as standard by the chemical engineering community. A typical example is the compact heat exchanger (3,4). These exchangers have been widely used for quite a long time in the food industry. In the chemical in-

dustry, however, process developers still often opt for conventional shell-and-tube units, even in cases where plate or spiral heat exchangers could easily be applied.

Process intensification concerns only engineering methods and equipment. So, for instance, development of a new chemical route or a change in composition of a catalyst, no matter how dramatic the improvements they bring to existing technology, do not qualify as process intensification.

We, therefore, offer the following definition:

Process intensification consists of the development of novel apparatuses and techniques that, compared to those commonly used today, are expected to bring *dramatic* improvements in manufacturing and processing, substantially decreasing equipment-size/production-capacity ratio, energy consumption, or waste production, and ultimately resulting in cheaper, sustainable technologies.

Or, to put this in a shorter form: any chemical engineering development that leads to a substantially smaller, cleaner, and more energy-efficient technology is process intensification!

As shown in Figure 2, the whole field generally can be divided into two areas:

- *process-intensifying equipment*, such as novel reactors, and intensive mixing, heat-transfer and mass-transfer devices; and
- *process-intensifying methods*, such as new or hybrid separations, integration of reaction and separation, heat exchange, or phase transition (in so-called multifunctional reactors), techniques using alternative energy sources (light, ultrasound, etc.), and new process-control methods (like intentional unsteady-state operation).

Obviously, there can be some overlap. New methods may require novel types of equipment to be developed and *vice versa*, while novel apparatuses already developed sometimes make use of new, unconventional processing methods.

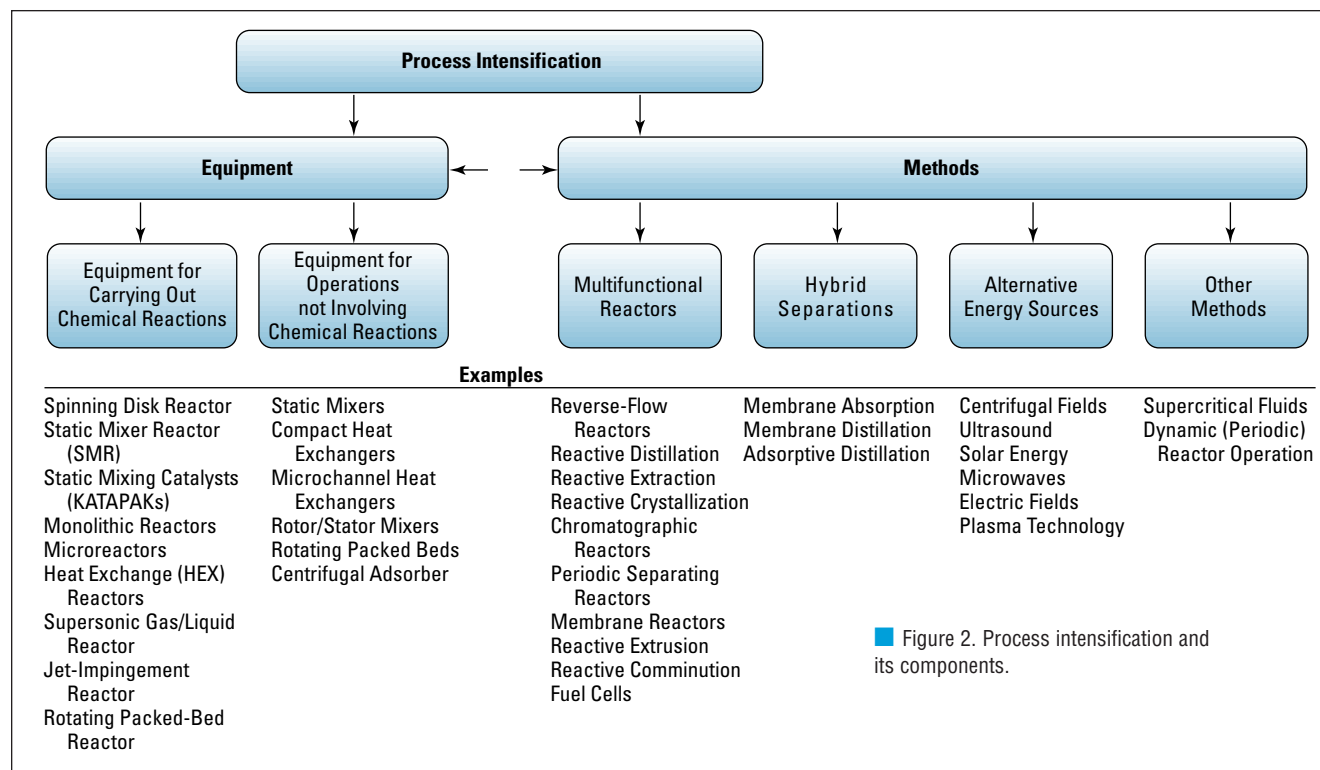

■ Figure 2. Process intensification and its components.

Process-intensifying equipment

Our earlier comment that Agricola’s woodcut shows how little stirring technology has progressed is not entirely true. In fact, the technology of stirring has been greatly intensified during the last 25 years, at least as far as liquid/liquid and gas/liquid systems. Surprisingly, this was achieved not by improving mechanical mixers but, quite the opposite, by abandoning them — in favor of static mixers (5). These devices are fine examples of process-intensifying equipment. They offer a more size- and energy-efficient method for mixing or contacting fluids and, today, serve even wider roles. For instance, the Sulzer (Winterthur, Switz.) SMR static-mixer reactor, which has mixing elements made of heat-transfer tubes (Figure 3), can successfully be applied in processes in which simultaneous mixing and intensive heat removal or supply are necessary, such as in nitration or neutralization reactions.



■ Figure 3. Proprietary reactor-mixer is a classic example of process-intensifying equipment. (Photo courtesy of Sulzer.)

One of the more important disadvantages of static mixers is their relatively high sensitivity to clogging by solids. Therefore, their utility for reactions involving slurry catalysts is limited. Sulzer solved this problem (at least partially) by developing structured packing that has good static-mixing properties and that simultaneously can be used as the support for catalytic material. Its family of open-crossflow-structure catalysts, so-called KATAPAKs (6) (Figure 4a), are used in some gas-phase exothermic oxidation processes traditionally carried out in fixed beds, as well as in catalytic distillation. KATAPAKs have very good mixing and radial heat-transfer characteristics (6). Their main disadvantage is their relatively low specific geometrical area, which is much lower than that of their most important rival in the field, monolithic catalysts (7) (Figure 4b).

Monolithic catalysts

Monolithic substrates used today for catalytic applications are metallic

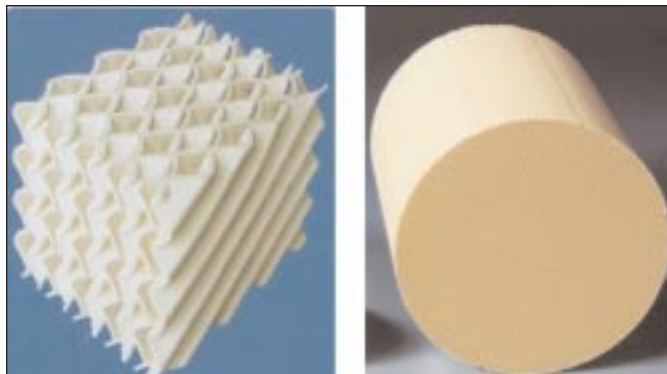

■ Figure 4. (a) Packing with integrated catalyst (photo courtesy of Sulzer.), and (b) monolithic catalyst (photo courtesy of Corning).

or nonmetallic bodies providing a multitude of straight narrow channels of defined uniform cross-sectional shapes. To ensure sufficient porosity and enhance the catalytically active surface, the inner walls of the monolith channels usually are covered with a thin layer of washcoat, which acts as the support for the catalytically active species.

The most important features of the monoliths are:

- very low pressure drop in single- and two-phase flow, one to two orders of magnitude lower than that

of conventional packed-bed systems;

- high geometrical areas per reactor volume, typically 1.5–4 times more than in the reactors with particulate catalysts;

- high catalytic efficiency, practically 100%, due to very short diffusion paths in the thin washcoat layer; and

- exceptionally good performance in processes in which selectivity is hampered by mass-transfer resistances.

Monolithic catalysts also can be installed in-line, like static mixing el-

ements, using the latter as gas/liquid dispersing devices. The in-line units offer additional advantages:

- low investment costs, because in-line monolithic reactors are ready-to-use modules that are installed as part of the pipelines;

- compact plant layout (in-line monolith reactors can even be placed underground, say, in cement ducts — see Figure 5);

- ability to meet much higher safety and environmental standards than conventional reactors (such as, for instance, by placing the reactor unit beneath ground level);

- very easy and quick replacement (*e.g.*, in case of catalyst deactivation) simply by swapping a piece of pipeline, instead of having to unload old and load new catalyst;

- the possibility of distributing multiple feed points along the reactor; and

- easy attainment of a near-to-plug-flow regime.

In a modeling study of an industrial gas/liquid process, Stankiewicz (8)

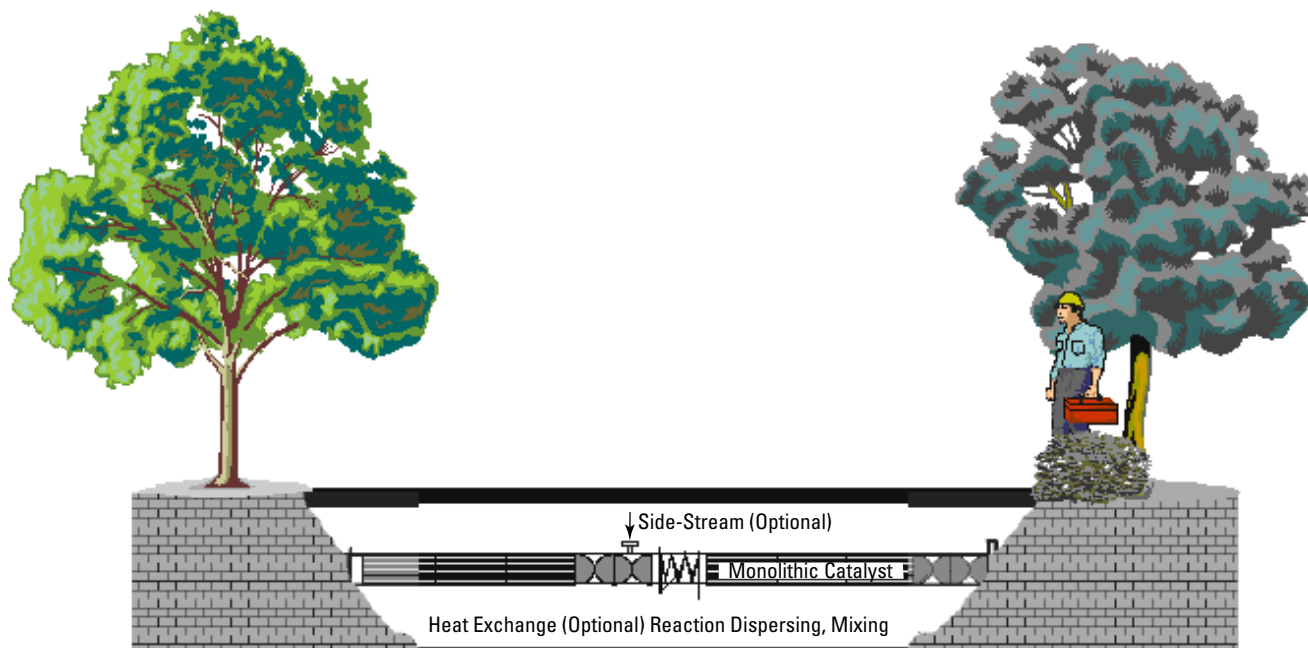

■ Figure 5. Cross-flow monolithic structure. (Illustration courtesy of Corning.)

gives a spectacular example of an approximately 100-fold reduction in reactor size from replacing a conventional system with an in-line monolithic unit.

One of the problems in monolith reactors, especially for gas-phase catalytic processes, is difficult heat removal due to the absence of radial dispersion. Monolith channels are fully separated from each other and, therefore, the only heat transport mechanism is the conductivity through the monolith material. For highly exothermic gas-phase reactions, so-called HEX reactors developed by BHR Group, Ltd. (Cranfield, U.K.) (9) present a promising option. In these reactors, one side of a compact heat exchanger is made catalytically active, either by washcoating or by introducing catalytically active elements (such as pellets or structured packings). A ceramic cross-flow monolith structure developed by Corning Inc. (Corning, NY) (10) (Figure 6) also potentially can be used as a catalytic reactor/heat exchanger, *e.g.*, for carrying out two chemical processes (exo- and endothermic) within one unit. Compared to conventional fixed-bed reactors, such reactors offer much better heat-transfer conditions — namely, heat-transfer coefficients typically of 3,500–7,500 W/m²K, and heat-transfer areas of up to 2,200 m².

Microreactors

Even higher values of heat-transfer coefficients than those in the HEX reactors can be achieved in microreactors. Here, values of up to 20,000 W/m²K are reported (11). Microreactors are chemical reactors of extremely small dimensions that usually have a sandwich-like structure consisting of a number of slices (layers) with micromachined channels (10–100 μm in dia.). The layers perform various functions, from mixing to catalytic reaction, heat exchange, or separation. Integration of these various functions within a single unit is one of the most important advantages of

microreactors. The very high heat-transfer rates achievable in microreactors allow for operating highly exothermic processes isothermally, which is particularly important in carrying out kinetic studies. Very low reaction-volume/surface-area ratios make microreactors potentially attractive for processes involving toxic or explosive reactants. The scale at which processes using batteries of multiple microreactors become economically and technically feasible still needs to be determined, though.

The geometrical configuration of microchannel heat exchangers (stacked cross-flow structures) resembles that of the cross-flow monoliths in Figure 6, although the materials and fabrication methods used differ. The channels in the plates of microchannel heat exchangers are usually around 1 mm or less wide, and are fabricated via silicon micromachining, deep X-ray lithography, or nonlithographic micromachining. Over the past few



■ Figure 6. Concept of an in-line catalytic reactor (8).

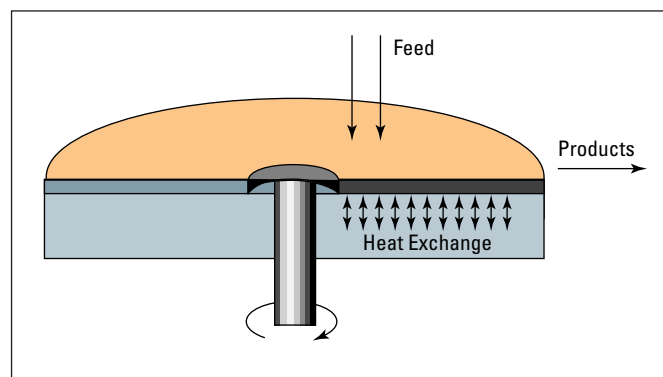

■ Figure 7. Schematic of the spinning-disk reactor.

years, Pacific Northwest National Laboratory (Richland, WA) has demonstrated microchannel heat exchangers in a planar sheet architecture that exhibit high heat fluxes and convective-heat-transfer coefficients. The reported values of heat-transfer coefficients in microchannel heat exchangers range from ≈10,000 to ≈35,000 W/m²K (4, 12).

Rotating devices

Almost as high heat-transfer coefficients are achievable in the spinning disk reactor (SDR) (13). This unit (see Figure 7) developed by Ramshaw's group at Newcastle University (Newcastle, U.K.) primarily is aimed at fast and very fast liquid/liquid reactions with large heat effect, such as nitrations, sulfonations, and polymerizations (*e.g.*, styrene polymerization (14)). In SDRs, a very thin (typically 100 μm) layer of liquid moves on the surface of a disk spinning at up to approximately 1,000 rpm. At very short residence times (typically 0.1 s), heat is efficiently removed from the reacting liquid at heat-transfer rates reaching 10,000 W/m²K. SDRs currently are being commercialized.

Other reactors especially dedicated to fast and very fast processes worth mentioning include: the supersonic gas/liquid reactor developed at Praxair Inc. (Danbury, CT) (15) for gas/liquid systems and the jet-impingement reactor of NORAM Engineering and Constructors (Vancouver, BC) (16,17) for liquid/liquid systems.

The former employs a supersonic shockwave to disperse gas into very tiny bubbles in a supersonic in-line mixing device, while the latter uses a system of specially configured jets and baffles to divide and remix liquid streams with high intensity. Rotor/stator mixers (18), which are aimed at processes requiring very fast mixing on a micro scale, contain a high-speed rotor spinning close to a motionless stator. Fluid passes through the region where rotor and stator interact and experiences highly pulsating flow and shear. In-line rotor/stator mixers resemble centrifugal pumps and, therefore, may simultaneously contribute to pumping the liquids.

Rotational movement and centrifugal forces are used not only in SDRs. High gravity (HIGEE) technology, which Imperial Chemical Industries (London) started working on in the late 1970s as a spinoff from a NASA research project on microgravity environment (19,20), has developed into one of the most promising branches of process intensification. HIGEE technology intensifies mass-transfer operations by carrying them out in rotating packed beds in which high centrifugal forces (typically 1,000 g) occur. This way, heat and momentum transfer as well as mass transfer can be intensified. The rotating-bed equipment, originally dedicated to separation processes (such as absorption, extraction, and distillation), also can be utilized for reacting systems (especially those that are mass-transfer limited). It potentially can be applied not only to gas/liquid systems, but also to other phase combinations including three-phase gas/liquid/solid systems. Recently, Chong Zheng's group at the HIGRAVITEC Center (Beijing) has successfully applied rotating (500–2,000 rpm) packed beds on a commercial scale for deaeration of flooding water in Chinese oil fields. There, rotating machines of ≈ 1 m dia. replaced conventional vacuum towers of ≈ 30 m height (21).

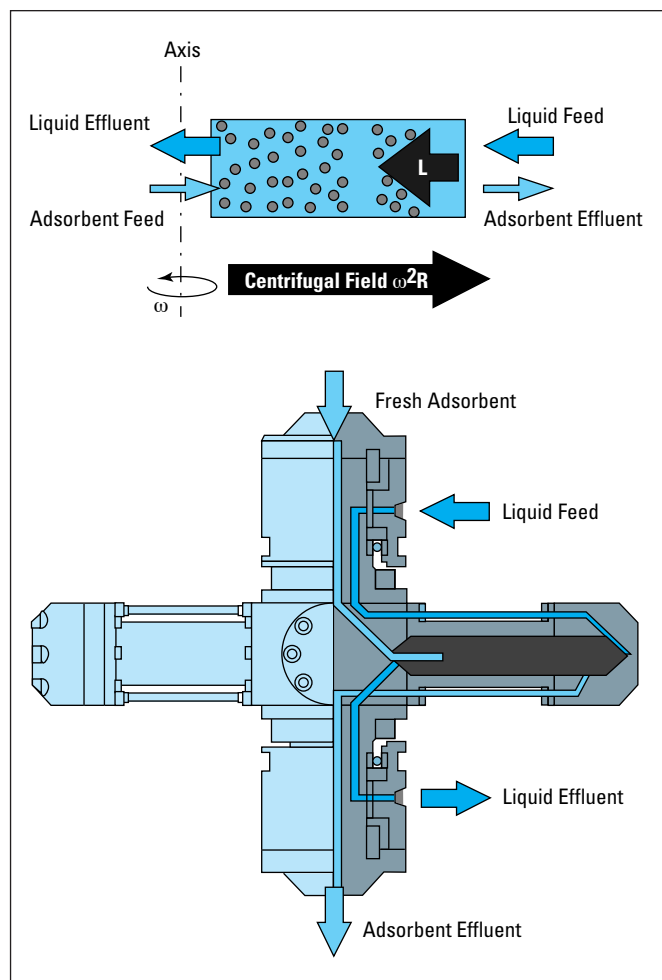

Figure 8. Centrifugal adsorber (23). (Drawing courtesy of Bird Engineering.)

Chong Zheng's group also has achieved successes in crystallization of nanoparticles: very uniform 15–30 nm crystals of CaCO_3 have been made in a rotating crystallizer at processing times 4–10 times shorter than those for a conventional stirred-tank process (22). Another interesting example here, also undergoing commercialization, is a centrifugal adsorber (Figure 8) developed at Delft University of Technology (Delft, The Netherlands) (23). This is a new continuous device for carrying out ion-exchange or adsorption processes. Using a centrifugal field to establish countercurrent flow between the liquid phase and the adsorbent enables use of very small (10–50 μm) adsorbent particles and design of extremely compact separation equipment with very short contact times and

high capacities (typically 10–50 m^3/h).

Process-intensifying methods

As highlighted in Figure 2, most process-intensifying methods fall into three well-defined areas: integration of reaction and one or more unit operations into so-called multifunctional reactors, development of new hybrid separations, and use of alternative forms and sources of energy for processing. Let's now take a closer look at each of these areas.

Multifunctional reactors

These can be described as reactors that, to enhance the chemical conversion taking place and to achieve a higher degree of integration, combine at least one more function (usually a

unit operation) that conventionally would be performed in a separate piece of equipment. A widely known example of integrating reaction and heat transfer in a multifunctional unit is the reverse-flow reactor (24). For exothermic processes, the periodic flow reversal in such units allows for almost perfect utilization of the heat of reaction by keeping it within the catalyst bed and, after reversion of the flow direction, using it for preheating the cold reactant gases. To date, reverse-flow reactors have been used in three industrial processes (24): SO₂ oxidation, total oxidation of hydrocarbons in off-gases, and NO_x reduction. The recent introduction of inert packing for heat exchange (25) has led to a "sandwich" reactor; it consists of three zones — a catalyst bed between two beds of packing of heat-accumulating material. The reverse-flow principle also has been applied in rotating monolith reactors, which are used industrially for removal of undesired components from gas streams and continuous heat regeneration (26). Studies also have been carried out on employing reversed-flow reactors for endothermic processes (27).

Reactive (catalytic) distillation is one of the better known examples of integrating reaction and separation, and is used commercially (28). In this case, the multifunctional reactor is a distillation column filled with catalytically active packing. In the column, chemicals are converted on the catalyst while reaction products are continuously separated by fractionation (thus overcoming equilibrium limitations). The catalyst used for reactive distillation usually is incorporated into a fiberglass and wire-mesh supporting structure, which also provides liquid redistribution and disengagement of vapor. Structured catalysts, such as Sulzer's KATAPAK, also are employed (29). The advantages of catalytic distillation units, besides the continuous removal of reaction products and higher yields due to the equilibrium shift, consist mainly of reduced energy requirements and

lower capital investment (30). Also, a reverse process to the one described above, that is, combination of reaction and condensation, has been studied for benzene oxidation to cyclohexane and for methanol synthesis (31,32). The number of processes in which reactive distillation has been implemented on a commercial scale is still quite limited — but the potential of this technique definitely goes far beyond today's applications.

Numerous research groups are investigating other types of combined reactions and separations, such as reactive extraction (33,34), reactive crystallization (35), and integration of reaction and sorption operations, for instance, in chromatographic reactors (36,37,38) and periodic separating reactors, which are a combination of a pressure swing adsorber with a periodic flow-forced packed-bed reactor (39).

Membrane reactors

Today, a huge research effort is devoted to membrane reactors (40). The membrane can play various functions in such reactor systems. It, for instance, can be used for selective *in-situ* separation of the reaction products, thus providing an advantageous equilibrium shift. It also can be applied for a controlled distributed feed of some of the reacting species, either to increase overall yield or selectivity of a process (e.g., in fixed-bed or fluidized-bed membrane reactors (41,42)) or to facilitate mass transfer (e.g., direct bubble-free oxygen supply or dissolution in the liquid phase via hollow-fiber membranes (43,44)). In addition, the membrane can enable *in-situ* separation of catalyst particles from reaction products (45)). Finally, the membrane can incorporate catalytic material, thus itself becoming a highly selective reaction-separation system. The scientific literature on catalytic membrane reactors is exceptionally rich (see, for instance, Ref. 46) and includes many very interesting ideas (such as heat- and mass-integrated combination of hydrogenation and dehydrogenation processes in a single

membrane unit). Yet, practically no large-scale industrial applications have been reported so far. The primary reason for this most definitely is the relatively high price of membrane units, although other factors, such as low permeability as well as mechanical and thermal fragileness, also play an important role. Further developments in the field of material engineering surely will change this picture.

Multifunctional reactors may integrate not only reaction and heat transfer or reaction and separation but also combine reaction and phase transition. A well-known example of such a combination is reactive extrusion. Reactive extruders are being increasingly used in the polymer industries. They enable reactive processing of highly viscous materials without requiring the large amounts of solvents that stirred-tank reactors do. Particularly popular are twin-screw extruders, which offer effective mixing, the possibility of operation at high pressures and temperatures, plug-flow characteristics, and capability of multistaging. Most of the reactions carried out in extruders are single- or two-phase reactions. New types of extruders with catalyst immobilized on the surface of the screws, however, may allow carrying out three-phase catalytic reactions (47).

Fuel cells present another example of multifunctional reactor systems. Here, integration of chemical reaction and electric power generation takes place (see, for instance, Ref. 48). Simultaneous gas/solid reaction and comminution in a multifunctional reactor also has been investigated (49).

Hybrid separations

Many of the developments in this area involve integration of membranes with another separation technique. In membrane absorption and stripping, the membrane serves as a permeable barrier between the gas and liquid phases. By using hollow-fiber membrane modules, large mass-transfer areas can be created, resulting in compact equipment. Besides, absorp-

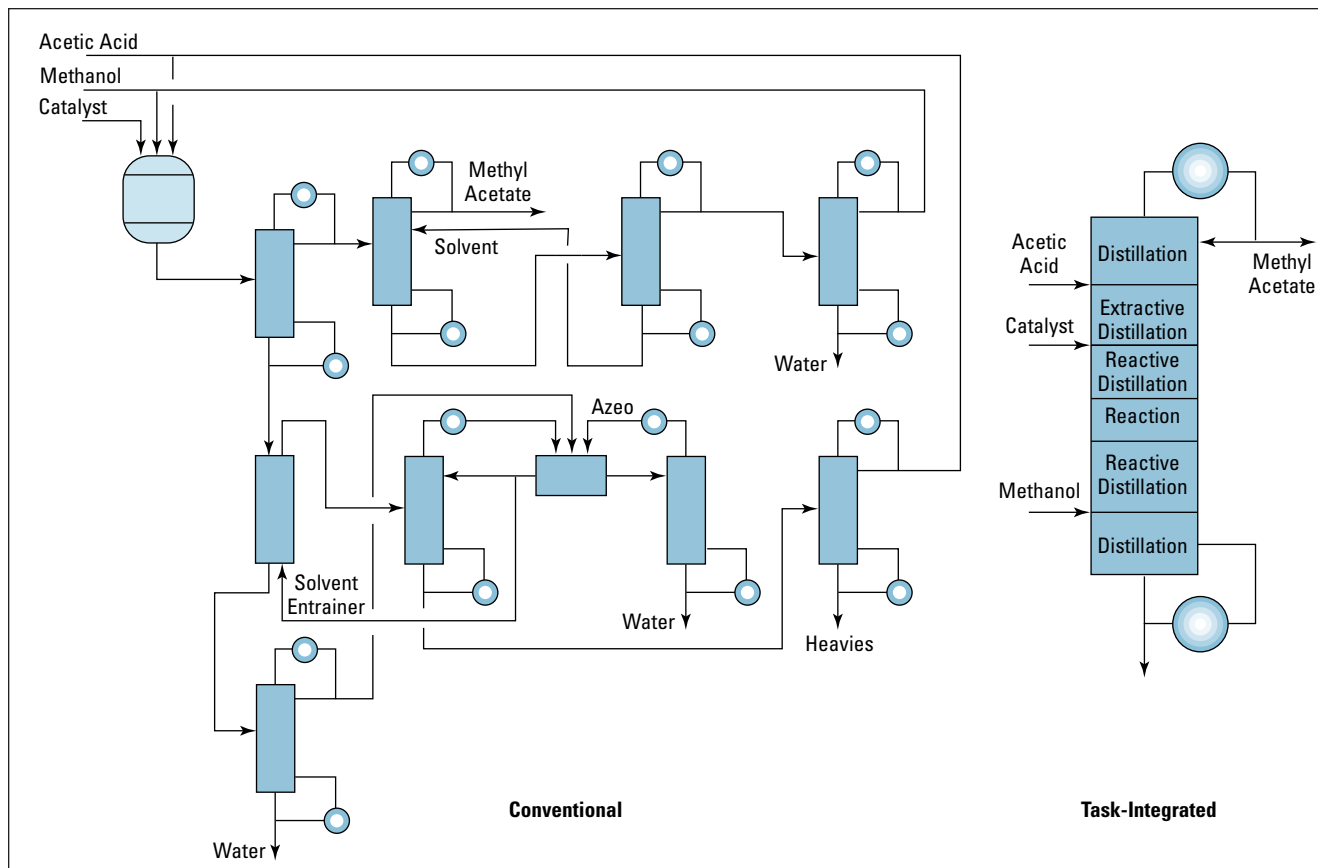

■ Figure 9. Task-integrated methyl acetate column is much simpler than conventional plant. (Drawing courtesy of Eastman Chemical (76).

tion membranes offer operation independent of gas- and liquid flow rates, without entrainment, flooding, channeling, or foaming (50,51).

Membrane distillation is probably the best known hybrid, and is being investigated worldwide (52,53). The technique is widely considered as an alternative to reverse osmosis and evaporation. Membrane distillation basically consists of bringing a volatile component of a liquid feed stream through a porous membrane as a vapor and condensing it on the other side into a permeate liquid. Temperature difference is the driving force of the process. Foster *et al.* (54) name four basic advantages of membrane distillation:

- 100% rejection of ions, macromolecules, colloids, cells, and other nonvolatiles;
- lower operating pressure across

the membrane than in the pressure-driven processes;

- less membrane fouling, due to larger pore size; and
- potentially lower operating temperatures than in conventional evaporation or distillation, which may enable processing of temperature-sensitive materials.

Among hybrid separations not involving membranes, adsorptive distillation (55) offers interesting advantages over conventional methods. In this technique, a selective adsorbent is added to a distillation mixture. This increases separation ability and may present an attractive option in the separation of azeotropes or close-boiling components. Adsorptive distillation can be used, for instance, for the removal of trace impurities in the manufacturing of fine chemicals; it may allow switching

some fine-chemical processes from batchwise to continuous operation.

Use of alternative forms and sources of energy

Several unconventional processing techniques that rely on alternative forms and sources of energy are of importance for process intensification. For instance, we already have discussed the potential benefits of using centrifugal fields instead of gravitational ones in reactions and separations.

Among other techniques, research on sonochemistry (the use of ultrasound as a source of energy for chemical processing) appears to be the most advanced. Formation of microbubbles (cavities) in the liquid reaction medium via the action of ultrasound waves has opened new possibilities for chemical syntheses. These cavities can be thought of as

high energy microreactors. Their collapse creates microimplosions with very high local energy release (temperature rises of up to 5,000 K and negative pressures of up to 10,000 atm are reported (56)). This may have various effects on the reacting species, from homolytic bond breakage with free radicals formation, to fragmentation of polymer chains by the shockwave in the liquid surrounding the collapsing bubble. For solid-catalyzed (slurry) systems, the collapsing cavities additionally can affect the catalyst surface — this, for example, can be used for *in-situ* catalyst cleaning/rejuvenation (57). A number of sonochemical reactor designs have been developed and studied (58). Sonochemistry also has been investigated in combination with other techniques, *e.g.*, with electrolysis for oxidation of phenol in wastewater (59). The maximum economically and technically feasible size of the reaction vessel still seems to be the determining factor for industrial application of sonochemistry.

Solar energy also may play a role in chemical processing. A novel high-temperature reactor in which solar energy is absorbed by a cloud of reacting particles to supply heat directly to the reaction site has been studied (60,61). Experiments with two small-scale solar chemical reactors in which thermal reduction of MnO_2 took place also are reported (60). Other studies describe, for example, the cycloaddition reaction of a carbonyl compound to an olefin carried out in a solar furnace reactor (62) and oxidation of 4-chlorophenol in a solar-powered fiberoptic cable reactor (63).

Microwave heating can make some organic syntheses proceed up to 1,240 times faster than by conventional techniques (64). Microwave heating also can enable energy-efficient *in-situ* desorption of hydrocarbons from zeolites used to remove volatile organic compounds (65).

Electric fields can augment process rates and control droplet size for a

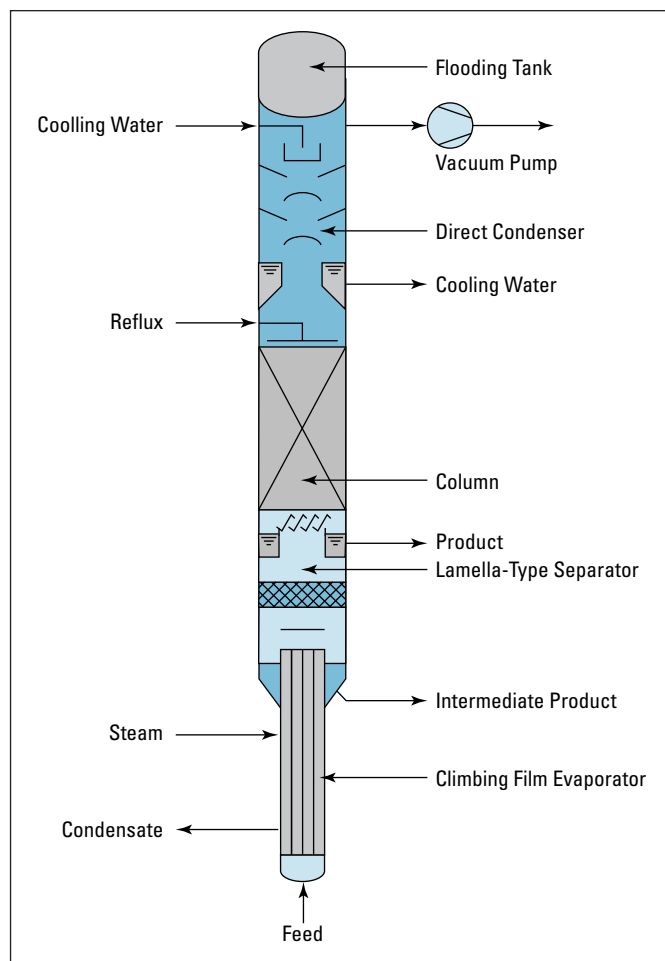

Figure 10. Single-unit distillation plant for hydrogen peroxide (77). (Drawing courtesy of Sulzer.)

range of processes, including painting, coating, and crop spraying. In these processes, the electrically charged droplets exhibit much better adhesion properties. In boiling heat transfer, electric fields have been successfully used to control nucleation rates (66). Electric fields also can enhance processes involving liquid/liquid mixtures, in particular liquid/liquid extraction (67) where rate enhancements of 200–300% have been reported (68).

Interesting results have been published concerning so-called Gliding Arc technology, that is, plasma generated by formation of gliding electric discharges (69,70,71). These discharges are produced between electrodes placed in fast gas flow, and offer a low-energy alternative for conventional high-energy-consuming high-temperature processes. Ap-

plications tested so far in the laboratory and on industrial scale include: methane transformation to acetylene and hydrogen, destruction of N_2O , reforming of heavy petroleum residues, CO_2 dissociation, activation of organic fibers, destruction of volatile organic compounds in air, natural gas conversion to synthesis gas, and SO_2 reduction to elemental sulfur.

Other methods

A number of other promising techniques do not fall within the three categories we have discussed. Some already are known and have been commercially proven in other industries. For instance, supercritical fluids (SCFs) are used industrially for the processing of natural products. Because of their unique properties, SCFs are attractive media for mass-

transfer operations, such as extraction (72) and chemical reactions (73). Many of the physical and transport properties of a SCF are intermediate between those of a liquid and a gas. Diffusivity in an SCF, for example, falls between that in a liquid and a gas; this suggests that reactions that are diffusion limited in the liquid phase could become faster in a SCF phase. SCFs also have unique solubility properties. Compounds that are largely insoluble in a fluid at ambient conditions can become soluble in the fluid at supercritical conditions. Conversely, some compounds that are soluble at ambient conditions can become less soluble at supercritical conditions. SCFs already have been investigated for a number of systems, including enzyme reactions, Diels-Alder reactions, organometallic reactions, heterogeneously catalyzed reactions, oxidations, and polymerizations. On the other hand, cryogenic techniques (distillation or distillation combined with adsorption (74)), today almost exclusively used for production of industrial gases, may in the future prove attractive for some specific separations in manufacturing bulk or fine chemicals.

Dynamic (periodic) operation of chemical reactors has interested researchers for more than three decades. In many laboratory trials, the intentional pulsing of flows or concentrations has led to a clear improvement of product yields or selectivities (75). Yet, despite a great amount of research, commercial-scale applications are scarce, and limited mainly to the reverse-flow reactors we have already discussed. One of the main reasons is that dynamic operation requires investments to synchronize nonstationary and stationary parts of the process. So, in general, steady-state operation is less expensive. There are cases, however, in which dynamic operation may prove advantageous, despite the tradeoffs involved (76).

Unit operations — an extinct species?

So far, we have highlighted a variety of equipment and techniques that should play a significant role in the intensification of chemical processes. This has not been a comprehensive cataloging, as new developments are regularly emerging from researchers worldwide. The examples do make clear, however, that hybrid operations,

that is, combinations of reactions and one or more unit operations, will play a dominant role in the future, process-intensive, sustainable CPI. Has the evolution of chemical engineering thus reached the point in which traditional unit operations will give way to these hybrid forms and become extinct? Our answer to this question is both *no* and *yes*.

No, because the development of these new, integrated apparatuses and techniques is and will remain deeply rooted in the knowledge of the basic, traditional unit operations. More than that, further research progress in process intensification will demand a parallel progress in fundamental unit-operation-based knowledge. Therefore, traditional unit operations will not disappear, at least not from chemical engineering research.

Yes, because some unit operations simply may become too expensive or inefficient to continue to be used commercially. These operations may well be marked for extinction in the industrial practice of the 21st century.

This scenario is even more likely for process equipment. Some types of apparatuses used now probably

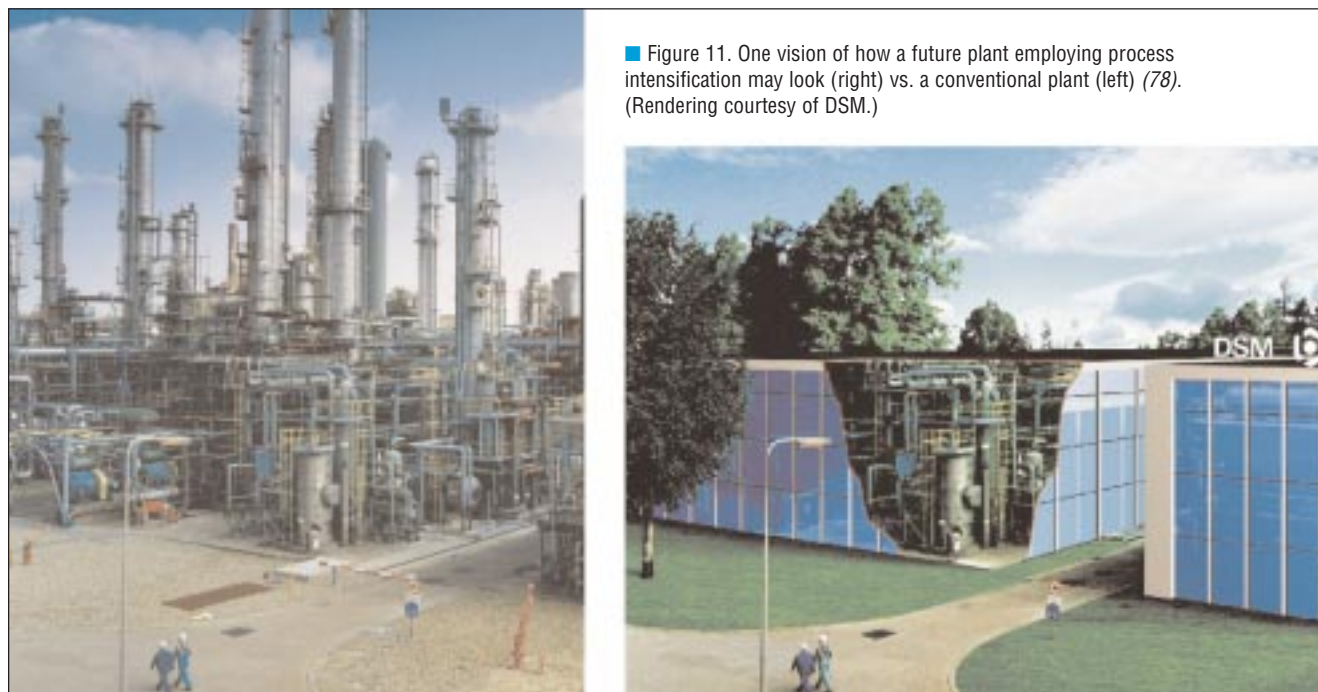

■ Figure 11. One vision of how a future plant employing process intensification may look (right) vs. a conventional plant (left) (78). (Rendering courtesy of DSM.)

Literature Cited

- Agricola, G.**, *De Re Metallica Libri XII*, Froben & Episopus, Basel, Switz. (1556).
- Ramshaw, C.**, "The Incentive for Process Intensification," *Proceedings, 1st Intl. Conf. Proc. Intensif. for Chem. Ind.*, **18**, BHR Group, London, p. 1 (1995).
- Thonon B.**, "Design Method for Plate Evaporators and Condensers," *Proceedings, 1st Intl. Conf. Proc. Intensif. for Chem. Ind.*, **18**, BHR Group, London, pp. 37–45 (1995).
- Thonon, B., and P. Mercier**, "Compact to Very Compact Heat Exchangers for the Process Industry," *Proceedings, 2nd Intl. Conf. Proc. Intensif. in Pract.*, **28**, BHR Group, London, pp. 49–62 (1997).
- "Mixing and Reaction Technology," Sulzer Chemtech, Winterthur, Switz. (1997).
- Stringaro, J.-P., P. Collins, and O. Bailer**, "Open Cross-Flow-Channel Catalysts and Catalyst Supports," in "Structured Catalysts and Reactors," A. Cybulski and J. A. Moulijn, eds., Marcel Dekker, New York, pp. 393–416 (1998).
- Irاندoust, S., A. Cybulski, and J. A. Moulijn**, "The Use of Monolithic Catalysts for Three-Phase Reactions," in "Structured Catalysts and Reactors," A. Cybulski and J. A. Moulijn, eds., Marcel Dekker, New York, pp. 239–265 (1998).
- Stankiewicz, A.**, "Process Intensification in In-Line Monolith Reactor," ISCRE-16, 16th Intl. Conf. Chem. React. Eng., Cracow, Poland, submitted to *Chem. Eng. Sci.*
- Phillips, C. H., G. Lauschke, and H. Peerhossaini**, "Intensification of Batch Chemical Processes by Using Integrated Chemical Reactor-Heat Exchangers," *Appl. Therm. Eng.*, **17** (8–10), pp. 809–824 (1997).
- Ketcham, T. D., and D. J. St. Julien**, "Method of Making a Cross-Flow Honeycomb Structure," U.S. Patent 5,660,778 (Aug. 26, 1997).
- Jäckel, K.-P.**, "Microtechnology: Application Opportunities in the Chemical Industry," Monograph Series **132**, Dechema, Frankfurt, pp. 29–50 (1995).
- Tonkovich, A. L. Y., C. J. Call, D. M. Jimenez, R. S. Wegeng, and M. K. Drost**, "Microchannel Heat Exchangers for Chemical Reactors," *AIChE Symp. Ser.*, **92** (310), AIChE, New York, pp. 119–125 (1996).
- Gibbard I.**, "Spinning Disk Reactors. New Opportunities for the Chemical Industry," presented at *Proc. Intensif.: Profits for the Chem. Ind.*, Rotterdam, Netherlands Agency for Energy and the Env., Sittard, The Netherlands (May 1998).
- Boodhoo, K. V. K., R. J. Jachuck, and C. Ramshaw**, "Spinning Disk Reactor for the Intensification of Styrene Polymerisation," *Proceedings, 2nd Intl. Conf. Proc. Intensif. in Pract.*, **28**, BHR Group, London, pp. 125–133 (1997).
- Cheng, A. T. Y.**, "A High-Intensity Gas-Liquid Tubular Reactor under Supersonic Two Phase Flow Conditions," *Proceedings, 2nd Intl. Conf. Proc. Intensif. in Pract.*, **28**, BHR Group, London, pp. 205–219 (1997).
- Hauptmann, E. G., J. M. Rae, and A. A. Guenkel**, "The Jet-Impingement Reactor, a New High Intensity Reactor for Liquid-Liquid Reaction Processes," *Proceedings, 1st Intl. Conf. Proc. Intensif. for the Chem. Ind.*, **18**, BHR Group, London, pp. 181–184 (1995).
- Rae, J. M., and E. G. Hauptmann**, "Jet Impingement Reactor," U.S. Pat. 4,994,242 (Feb. 19, 1991).
- Bourne, J. R., and M. Studer**, "Fast Reactions in Rotor-Stator Mixers of Different Size," *Chem. Eng. Proc.*, **31** (5), pp. 285–296 (1992).
- Ramshaw, C.**, "'Higee' Distillation — an Example of Process Intensification," *The Chem. Eng.*, **389** (2), pp. 13–14 (1983).
- Ramshaw, C., and R. H. Mallinson**, "Mass Transfer Apparatus and its Use," Eur. Pat. 0,002,568 (June 20, 1984).
- Zheng, C., K. Guo, Y. Song, X. Zhou, D. Al, Z. Xin, and N. C. Gardner**, "Industrial Practice of HIGRAVITEC in Water Deaeration," *Proceedings, 2nd Intl. Conf. Proc. Intensif. in Pract.*, **28**, BHR Group, London, pp. 273–287 (1997).
- Chen, J., Y. Wang, Z. Jia, and C. Zheng**, "Synthesis of Nano-Particles of CaCO₃ in a Novel Reactor," *Proceedings, 2nd Intl. Conf. Proc. Intensif. in Pract.*, **28**, BHR Group, London, pp. 157–161 (1997).
- Bisschops, M. A. T., L. A. M. Van der Wiele, and K. C. A. M. Luyben**, "Centrifugal Adsorption Technology for the Removal of Volatile Organic Compounds from Water," *Proceedings, 2nd Intl. Conf. Proc. Intensif. in Pract.*, **28**, BHR Group, London, pp. 299–307 (1997).
- Matros, Y. S., and G. A. Bunimovich**, "Reverse-Flow Operation in Fixed-Bed Catalytic Reactors," *Catal. Rev.-Sci. Eng.*, **38** (1), pp. 1–68 (1996).
- Matros, Y. S., and G. A. Bunimovich**, "Control of Volatile Organic Compounds by the Catalytic Reverse Process," *I. & E. C. Res.*, **34** (5), pp. 1,630–1,640 (1995).
- "Comprehensive Activities in the Engineering and Installation of Efficient Energy Systems," Leaflet 2016/3.0/8.90/Br, Kraftanlagen Heidelberg, Heidelberg, Germany (1990).
- Kolios, G., and G. Eigenberger**, "Styrene Synthesis in a Reverse-Flow Reactor," *Chem. Eng. Sci.*, **54** (13-14), pp. 2,637–2,646 (1999).
- DeGarmo, J. L., V. N. Parulekar, and V. Pinjala**, "Consider Reactive Distillation," *Chem. Eng. Progress*, **88** (3), pp. 43–50 (Mar. 1992).
- Kreul, L. U., A. Górak, and P. I. Barton**, "Katalytische Destillation in Modernen Strukturiert-Katalytischen Packungen," Jahrestagungen '98, **II**, Dechema, Frankfurt, p. 913 (1998).
- Stadig, W. P.**, "Catalytic Distillation: Combining Chemical Reaction with Product Separation," *Chem. Proc.*, **50** (2), pp. 27–32 (1987).
- Halloin, V. L., H. Ben Armor, and S. J. Wajc**, "Reactor-Condenser," *Proceedings, 5th World Congress of Chem. Eng.*, San Diego, **III**, pp. 232–237 (1996).
- Ben Armor, H., and V. L. Halloin**, "Methanol Synthesis in a Multifunctional Reactor," *Chem. Eng. Sci.*, **54** (10), pp. 1,419–1,423 (1999).
- Minotti, M., M. F. Doherty, and M. F. Malone**, "Design for Simultaneous Reaction and Liquid-Liquid Extraction," *I. & E. C. Res.*, **37** (12), pp. 4,746–4,755 (1998).
- Samant, K. D., and K. M. Ng**, "Systematic Development of Extractive Reaction Process," *Chem. Eng. Technol.*, **22** (10), pp. 877–880 (1999).
- Kelkar, V. V., K. D. Samant, and K. M. Ng**, "Design of Reactive Crystallization Processes," presented at AIChE Ann. Mtg., Los Angeles (1997).
- Mazotti, M., A. Kruglov, B. Neri, D. Gelosa, and M. Morbidelli**, "A Continuous Chromatographic Reactor: SMBR," *Chem. Eng. Sci.*, **51** (10), pp. 1,827–1,836 (1996).
- Meurer, M., U. Altenhöner, J. Strube, and H. Schmidt-Traub**, "Dynamic Simulation of Simulated Moving Bed Chromatographic Reactors," *J. of Chromatogr.*, **769** (1), pp. 71–79 (1997).
- Juza, M., M. Mazzotti, and M. Morbidelli**, "Simulated Moving Bed Technology — Analytical Separations on a Large Scale," *GIT Special. Chromatografie*, **18** (2), pp. 70–76 (1998).
- Vaporciyan, G. G., and R. H. Kadlec**, "Periodic Separating Reactors: Experiments and Theory," *AIChE J.*, **35** (1), pp. 831–844 (1989).
- Sirkar, K. K., P. V. Shanbhag, and A. S. Kovvali**, "Membrane in a Reactor: A Functional Perspective," *I. & E. C. Res.*, **38** (10), pp. 3,715–3,737 (1999).

41. Tsotsis, T. T., A. M. Champagnie, S. P. Vasileiadis, Z. D. Ziaka, and R. G. Minet, "Packed Bed Catalytic Membrane Reactors," *Chem. Eng. Sci.*, **47** (9–11), pp. 2,903–2,908 (1992).
42. Adris, A.-E. M., and J. R. Grace, "Characteristics of Fluidized-Bed Membrane Reactors: Scale-up and Practical Issues," *I. & E. C. Res.*, **36** (11), pp. 4,549–4,556 (1997).
43. Ahmed, T., and M. J. Semmens, "Use of Sealed End Hollow Fibres for Bubbleless Membrane Aeration: Experimental Studies," *J. Membr. Sci.*, **69** (1), pp. 1–10 (1992).
44. Shanbhang, P. V., A. K. Guha, and K. K. Sirkar, "Single-Phase Membrane Ozonation of Hazardous Organic Compounds in Aqueous Streams," *J. Haz. Mat.*, **41** (2), pp. 95–104 (1995).
45. Huizenga, P., "The Continuously Filtering Slurry Reactor," PhD Diss., University of Twente, Enschede, The Netherlands (1998).
46. Falconer, J. L., R. D. Noble, and D. P. Sperry, "Catalytic Membrane Reactors," in "Membrane Separations Technology. Principles and Applications," R. D. Noble and S. A. Stern, eds., Elsevier, Amsterdam, pp. 669–712 (1995).
47. Ebrahimi-Moshkabad, M., and J. M. Winterbottom, "The Behaviour of an Inter-meshing Twin Screw Extruder with Catalyst Immobilised Screws as Three-Phase Reactor," *Cat. Today*, **48** (1–4), pp. 347–355 (1999).
48. Tagawa, T., K. K. Moe, M. Ito, and S. Goto, "Fuel Cell Type Reactor for Chemicals-Energy Co-generation," *Chem. Eng. Sci.*, **54** (10), pp. 1,553–1,557 (1999).
49. Uhde, G., K. Sundmacher, and U. Hoffmann, "Simultaneous Gas-Solid Reaction and Comminution: A Novel Multifunctional Reactor," *Proceedings, 5th World Congress of Chem. Eng.*, San Diego, I, pp. 167–172 (1996).
50. Jansen, A. E., R. Klaassen, and P. H. M. Feron, "Membrane Gas Absorption — a New Tool in Sustainable Technology Development," *Proceedings, 1st Intl. Conf. Proc. Intensif. for the Chem. Ind.*, **18**, BHR Group, London, pp. 145–153 (1995).
51. Poddar, T. K., S. Majumdar, and K. K. Sirkar, "Removal of VOCs from Air by Membrane-Based Absorption and Stripping," *J. Membr. Sci.*, **120** (4), pp. 221–237 (1996).
52. Lawson, K. W., and D. R. Lloyd, "Membrane Distillation: A Review," *J. Membr. Sci.*, **124** (1), pp. 1–25 (1997).
53. Godino, P., L. Peña, and J. I. Mengual, "Membrane Distillation: Theory and Experiments," *J. Membr. Sci.*, **121**, pp. 89–93 (1996).
54. Foster, P. J., A. Burgoyne, and M. M. Vahdati, "A New Rationale for Membrane Distillation Processing," presented at *Intl. Conf. on Proc. Innov. and Intensif.*, Manchester, U.K., I.Chem.E., Rugby, U.K. (1998).
55. Yu, K. T., M. Zhou, and C. J. Xu, "A Novel Separation Process: Distillation Accompanied by Adsorption," *Proceedings, 5th World Congress of Chem. Eng.*, San Diego, I, pp. 347–352 (1996).
56. Mason, T. J., "Practical Sonochemistry. User's Guide to Applications in Chemistry and Chemical Engineering," Ellis Horwood, New York (1991).
57. Mikkola, J. P., and T. Salmi, "In situ Ultrasonic Catalyst Rejuvenation in Three-Phase Hydrogenation of Xylose," *Chem. Eng. Sci.*, **54** (10), pp. 1,583–1,588 (1999).
58. Horst, C., Y.-S. Chen, U. Kunz, and U. Hoffmann, "Design, Modeling and Performance of a Novel Sonochemical Reactor for Heterogeneous Reactions," *Chem. Eng. Sci.*, **51** (10), pp. 1,837–1,846 (1996).
59. Trabelsi, F., H. Ait-Lyazidi, B. Ratsimba, A. M. Wilhelm, H. Delmas, P.-L. Fabre, and J. Berlan, "Oxidation of Phenol in Wastewater by Sono-electrochemistry," *Chem. Eng. Sci.*, **51** (10), pp. 1,857–1,865 (1996).
60. Ganz, J., P. Haueter, A. Steinfeld, and D. Wullemin, "A Novel Volumetric Solar Reactor for Metal Oxides Reduction," *Proceedings, 7th Intl. Symp. Solar Thermal Conc. Tech.*, Moscow, **4**, pp. 826–832 (1994).
61. Meier, A., J. Ganz, and A. Steinfeld, "Modeling of a Novel High-Temperature Solar Chemical Reactor," *Chem. Eng. Sci.*, **51** (11), pp. 3,181–3,186 (1996).
62. Pohlmann, B., H.-D. Scharf, U. Jarolimek, and P. Mauermann, "Photochemical Production of Fine Chemicals with Concentrated Sunlight," *Sol. Energy*, **61** (3), pp. 159–168 (1997).
63. Peill, N. J., and M. R. Hoffmann, "Solar-Powered Photocatalytic Fiber-Optic Cable Reactor for Waste Stream Remediation," *J. Sol. Energy Eng.*, **119** (3), pp. 229–236 (1997).
64. Gedye, R. N., F. E. Smith, and K. C. Westaway, "The Rapid Synthesis of Organic Compounds in Microwave Ovens," *Can. J. Chem.*, **66** (1), pp. 17–26 (1988).
65. Curtis, W., C. Lin, R. L. Laurence, S. Yngvesson, and M. Turner, "Microwave Sorption Reactor Engineering," presented at AICHE Ann. Mtg., Los Angeles (1997).
66. Karayiannis, T. G., M. W. Collins, and P. G. Allen, "Electrohydrodynamic Enhancement of Nucleate Boiling Heat Transfer in Heat Exchangers," *Heat Technol.(Bologna)*, **7** (2), pp. 36–44 (1989).
67. Weatherley, L. R., "Electrically Enhanced Mass Transfer," *Heat Recov. Sys. & CHP*, **13** (6), pp. 515–537 (1991).
68. Yamaguchi, M., "Electrically Aided Extraction and Phase Separation Equipment," in "Liquid-Liquid Extraction Equipment," J. C. Godfrey and M. J. Slater, eds., Wiley, New York, pp. 585–624 (1994).
69. Czernichowski, A., and T. Czech, "Plasma Assisted Incineration of Some Organic Vapours in Gliding Discharges Reactor," *Polish J. Appl. Chem.*, **39** (4), pp. 585–590 (1995).
70. Czernichowski, A., and H. Leuseur, "Multi-Electrodes High Pressure Gliding Arc Reactor and its Applications for Some Waste Gas and Vapor Incineration," *Proceedings, Plasma Appl. to Waste Water Treat.*, Idaho Falls, ID, pp. 1–13 (1991).
71. Czernichowski, A., J. Polaczek, and T. Czech, "Cold-Plasma Reduction of Flue-Gas SO_x to Elemental Sulfur," *Proceedings, ISPC-11, 11th Intl. Symp. Plasma Chem.*, Loughborough, U.K., I. U. P. A. C., Research Triangle Park, NC, pp. 674–679 (1993).
72. McHugh, M. A., and V. J. Krukonic, "Supercritical Fluid Extraction," Butterworth-Heinemann, Boston (1994).
73. Savage, P. E., S. Gopalan, T. I. Mizan, C. J. Martino, and E. E. Brock, "Reactions at Supercritical Conditions: Applications and Fundamentals," *AICHE J.*, **41** (7), pp. 1,723–1,178 (1995).
74. Jain, R., and J. T. Tseng, "Production of High Purity Gases by Cryogenic Adsorption," presented at AICHE Ann. Mtg., Los Angeles (1997).
75. Silveston, P. L., "Composition Modulation in Catalytic Reactors," Gordon & Breach, Amsterdam (1998).
76. Zwijnenburg, A., A. Stankiewicz, and J. A. Moulijn, "Dynamic Operation of Chemical Reactors: Friend or Foe?," *Chem. Eng. Progress*, **94** (11), pp. 39–47 (1998).
77. Siirola, J. J., "Synthesis of Equipment with Integrated Functionality," presented at *Proc. Intensif.: Profits for the Chem. Ind.*, Rotterdam, Netherlands Agency for Energy and the Env., Sittard, The Netherlands (May 1998).
78. Meili, A., "Practical Process Intensification Shown with the Example of a Hydrogen Peroxide Distillation System," *Proceedings, 2nd Intl. Conf. Proc. Intensif. in Pract.*, BHR Group, London, **28**, pp. 309–318 (1997).
79. "Sustainable Technological Development at DSM: The Future Is Now," *DSM Magazine*, No. 83, pp. 4–10 (Feb. 1999).

will disappear from plants because of process intensification. They will give way to new task-integrated devices. A spectacular example of such task integration already applied on commercial scale is the new methyl acetate process of Eastman Chemical Co.; seven tasks have been integrated into a single piece of equipment (77) as illustrated in Figure 9. A single-unit hydrogen-peroxide distillation plant (Figure 10) developed by Sulzer (78) is another example of such changes already taking place in industry.

The CPI skyline also is likely to change. New, highly efficient devices may replace tens-of-meters tall reactors and separation columns. And, plants in which reactions take place underground in pipeline reactors and products are separated in 1–2 m dia. rotating devices are certainly conceivable.

Will further developments in the CPI resemble those in the electronics industry and will process plants and equipment become increasingly miniaturized as has happened in the fields of information and communication? The answer very much will depend upon the existence of sufficiently strong drivers to stimulate or force such changes. In case of information and communication, a significant number of such drivers existed in the past, the cold war and the space race of the super powers to mention only two. This led to revolutionary changes, particularly in materials technologies, that eventually brought to our desks computers much faster and more powerful than their multistory-building-size ancestors. In the case of the CPI, the most probable scenario is that society itself will spur radical changes. With ever-increasing population density and growing environmental consciousness in society, there will be no room (literally and figuratively) for the huge, inefficient chemical factories producing tons of wastes per ton of useful product. Miniaturization and process intensification in general will become inevitable.

The role of education

To make these society-driven changes come true, the teaching of chemical engineering also will have to undergo some essential revision. First, future chemical engineers will have to be taught an integrated, task-oriented approach to plant design, not today's sequential, operation-oriented one. (Eastman's process in Figure 9 clearly illustrates the difference between these two approaches.) To achieve this goal, the education of future engineers must place much more stress on creative, nonschematic thinking, not confined to known types of equipment and methods. Second, future chemical engineers must gain a much deeper knowledge and understanding of process chemistry (and chemists must become much more familiar with the related engineering issues) — because, in the highly efficient chemical processes of the coming decade, chemistry and engineering will be meeting each other at the molecular level, not at the apparatus level as they do today. Third, material engineering will play an essential role in the development of new chemical processes at the molecular level (*e.g.*, engineering of catalysts) and, therefore, will become a much more important part of the chemical engineering curriculum.

Meeting these demands will require concerted effort and some crucial cultural changes from universities to find the new ways of teaching chemical engineering and chemistry. But, these steps are essential if the CPI are to prosper and realize industrial visions of compact, efficient, sustainable technologies like the one recently presented by DSM (79) (Figure 11) come true.

Epilogue: the legacy of Agricola

Now, looking again at Figure 1, we have a different perspective. What Agricola showed in his woodcut is a highly task-integrated and energy-efficient continuous plant for gold recovery! The energy-efficient integra-

tion of three different processing tasks takes place via the water-wheel *A* that simultaneously supplies power to crush ore in the crusher *C*, grind it in grinder *K*, and recover gold by mixing the ore with mercury in the three-stage system of stirred vessels *O*.

And, perhaps only now at the very end of our article, can we say what process intensification really is. It is thinking progressively about processes and viewing them integrally through the tasks they have to fulfill and the results they have to deliver.

CEP

A. I. STANKIEWICZ is a senior researcher with DSM Research in Geleen, The Netherlands (31 46 4760820; Fax: 31 46 4760809; E-mail: Andrzej.Stankiewicz@dsm-group.com) and associate professor in the Industrial Catalysis Section of Delft University of Technology, Delft, The Netherlands (31 15 2785006; Fax: 31 15 2784452, E-mail: A.Stankiewicz@stm.tudelft.nl). He is author or co-author of over 60 papers on chemical reaction engineering and industrial catalysis, and holds several patents in the field. He received a PhD in chemical engineering from the Industrial Chemistry Research Inst., Warsaw. He is a member of AIChE.

J. A. MOULIJN is professor of industrial catalysis at Delft University of Technology, Delft, The Netherlands (31 15 2785008; Fax: 31 15 2784452; E-mail: J.A.Moulijn@stm.tudelft.nl). The editor of five books, the author or co-author of over 400 professional papers, and the holder of several international patents in reactor design, zeolitic membranes, and catalysis development, he is a chief technical advisor to the U. N. Devel. Org., and serves as European editor of *Fuel Processing Technology*. He holds a PhD in chemical engineering from the Univ. of Amsterdam, and is a member of AIChE.

Related Web Site

www.ncl.ac.uk/pin/ administered by the Dept. of Chemical and Process Engineering of the Univ. of Newcastle started up in April. This site, under the guidance of Colin Ramshaw, professor of intensive processing, will contain research and industry news, technical information, articles on new technologies, a directory of equipment makers, plus links to other resources for process intensification.