

International Project Management

EPC Heavy Industrial Projects

This is NOT Ordinary Work

By Bob Stevens

Project Engineering Manager (Retired)

Bechtel Corporation - 01/26/2021

This International Projects Presentation is:

- Everything on Last Year's Project Management Presentation

PLUS

- What Sets International Projects Apart?
- What are Unique Encounters and Consideration?
- Examples and Stories That Will Surprise You and Enlighten You

No Confidential nor Secret Information

Safety is NO Accident

Preface

- Personal Experience and Opinions,
Not Opinions of Any Company nor Group.
- **No Prejudice, But Honest Observations**
- Friends in All Countries, Even Today – Great People
- I Will Be Speaking of:
 - Governments
 - Cultural
 - Transition from Third and Developing to First World - Clashes

Have Visa, Will Travel

Lived, Traveled, or Worked On (16 Countries)

- USA
- Mexico
- Chile
- Peru
- Egypt
- Nigeria
- Angola
- Mozambique
- Austria
- Romania
- Russia
- China
- India
- Thailand
- Australia
- The Moon (Did not Travel nor Live There)



Human Resources Roles / Jobs

- *All the standard items, plus:*
- Visas and Visa Renewals
 - Meet and Greet
- Meeting the Chief Of Police – Relationship Building
- Security
- Hoteling / Meals
 - Pioneer Camp
 - Main Hoteling and Meals – Camp or In Town
 - Camp Habitation Building Requirements, Mess Hall, Canteen, Beer Hall, Recreation, Tie to the Community

Human Resources Roles / Jobs (con't)

- Arrange Medical
 - Shots – International Certificate of Vaccination (The Yellow Card)
 - Routine and Pre-Travel Exams
 - Illness and Injury
 - Air Evacuation (e.g., SOS)
- Transportation
 - Vehicles
 - Drivers
 - Driving Permits
- Local Hazards / Learning to Cuss Like a Native
 - Don't Drink the Water / Don't Breathe the Air

Human Resources Roles / Jobs (con't)

- Wage and Benefit – Recruiting / Retaining Expat
 - Uplift (e.g., 15%)
 - Extended Work Week (e.g., 60 hours)
 - $15\% + 60/40 = 165\%$ of Base Pay
- R&R and Home Leave every few months
- Taxes
 - In Country Legal Entity
 - Home Country Legal Entity – Retainer
 - Gross Up to Equivalent for Taxes

Human Resources Roles / Jobs (con't)

- Wage and Benefit (Non-Manual) – Recruiting In Country
 - Wage Structure Comparable to Local Wages
 - Often a Fraction of US Expat Wages
 - Usually On The High End
 - (e.g., Construction Manager Administrative Assistant – More Pay than when she was a Teacher)
 - Fluently Bilingual
 - Extended Work Week (e.g., 60 hours)

Human Resources Roles / Jobs (con't)

- Medical / Fire / Emergency on Site
 - Local Hospital and Doctor
 - On Site Paramedics / Nurse / Ambulance
 - Fire Department
 - Snake Wranglers
- Force Report – Contacts – Primary / Secondary Evacuation Plans
 - Call Tree – **9/11 Example (Upcoming)**
- SOS Daily Report of Dangers and Hazards.
- Local Country
- US Dept of State

International SOS – Daily Digest (Usually 25 – 50 pages)

AFRICA

Advisories

Bukina Faso: Polio Outbreak

Notices

Mali: Fresh attack highlights need to avoid. EXTREME travel risk regions

AFRICA

Advisories

Bukina Faso: Ongoing Polio Outbreak. Several cases reported in multiple locations.

Advice (4 bullet points)

More Detail (6 long paragraphs)

Notices

Mali: Five Malian troops injured when their vehicle struck a bomb near Dioungani commune. Etc.

Advice

More Detail

Recruiting and Training Craft Labor Issues

- Insufficient Numbers in Country With Skills
 - Pipefitters, Electricians, Ironworkers, etc.
- Bring In International Construction Labor
 - Labor and Cultural Issues
 - Feeling of “Encroaching on Our Turf”
 - Lack of Skills Domestically
- Training of Local Craft
 - Safety is a Foreign Concept
- Premium Pay and Benefits

Craft Labor Issues

- On Site Labor vs Package Fabrication Shops
- Building with Cranes vs. Bamboo Manually Erected

- Four Hour vs. Two Hour Siesta
- Breaks and Settings for part of the 5 Prayers a Day
- Paid Weekly – End of Week Morning vs. Afternoon

- Ability to Transfer to other Projects
 - In Country
 - Other Countries

Government Issues

- Needing More Land for the Flare – How Obtained
- Stepladder
 - Domestic Metal, Only
 - Imported Fiberglass
 - Destructive Examination
 - Not Sampling, every Ladder
 - Building Our Own Ladders

Government Issues (Con't)

- Permits, Government Regulations
 - Camp Habitation – Trailers vs 40-foot Shipping containers
- Different Codes, Extra Regulations
- Police – “The Bite” or “A Tip”



Safety

- Beyond Hard Hats and Safety Glasses (e.g., Parliament)
 - Steel Toed Boots vs. Flip Flops or Bare Feet
 - Confined Space
 - Shoring Trenches
 - Not Walking Under Loads
 - Safety Harness

Safety Harness



Security

- Driving “Rules of the Road”
- Who is “at fault” and financially responsible for a traffic accident?
 - Deep Pockets – Even if NOT involved in accident
- If a full Moon – Drive with your Headlights Off
- North Coast Road – 3 lanes each way (not limited access)
 - Never Drive in the Right Lane – Why?
 - A. It is for Parked Cars
 - B. It is for Donkey Carts
 - C. It is for People Standing Talking
 - D. It is for Vehicles Going the Wrong Way
 - E. All of the Above

Security

- Assume Everything is Bugged
 - Phones
 - Emails
 - Rooms at Work (e.g., Needing a Drawing)
 - Hotel Rooms
 - What can you say?
 - Where can you talk?

Security (con't)

- Guarding Construction – Controlled Access
- During In Country Meeting – Who is On the Take from Whom?
 - Compare Notes among Expats – Great After Dinner Conversation
 - Purpose of Project – Build Plant or Maximize Bribes?
 - How to Make Certain We Get Paid?
- Security From Airport – Private Security, Armored SUV (as needed)

Security (Con't)

Where Were You on 9/11?

- On Construction Site – 4 pm in Conference Room
- Hotel to Chalets, Beach Assault
- Five Layers of Security - Hotel
- Primary and Secondary Evacuation Updated
- Travel to US – Different Airport, Check in with Head of Security

General Jim
Mattis

USMC (Ret.)

Sec of Defense
(Former)

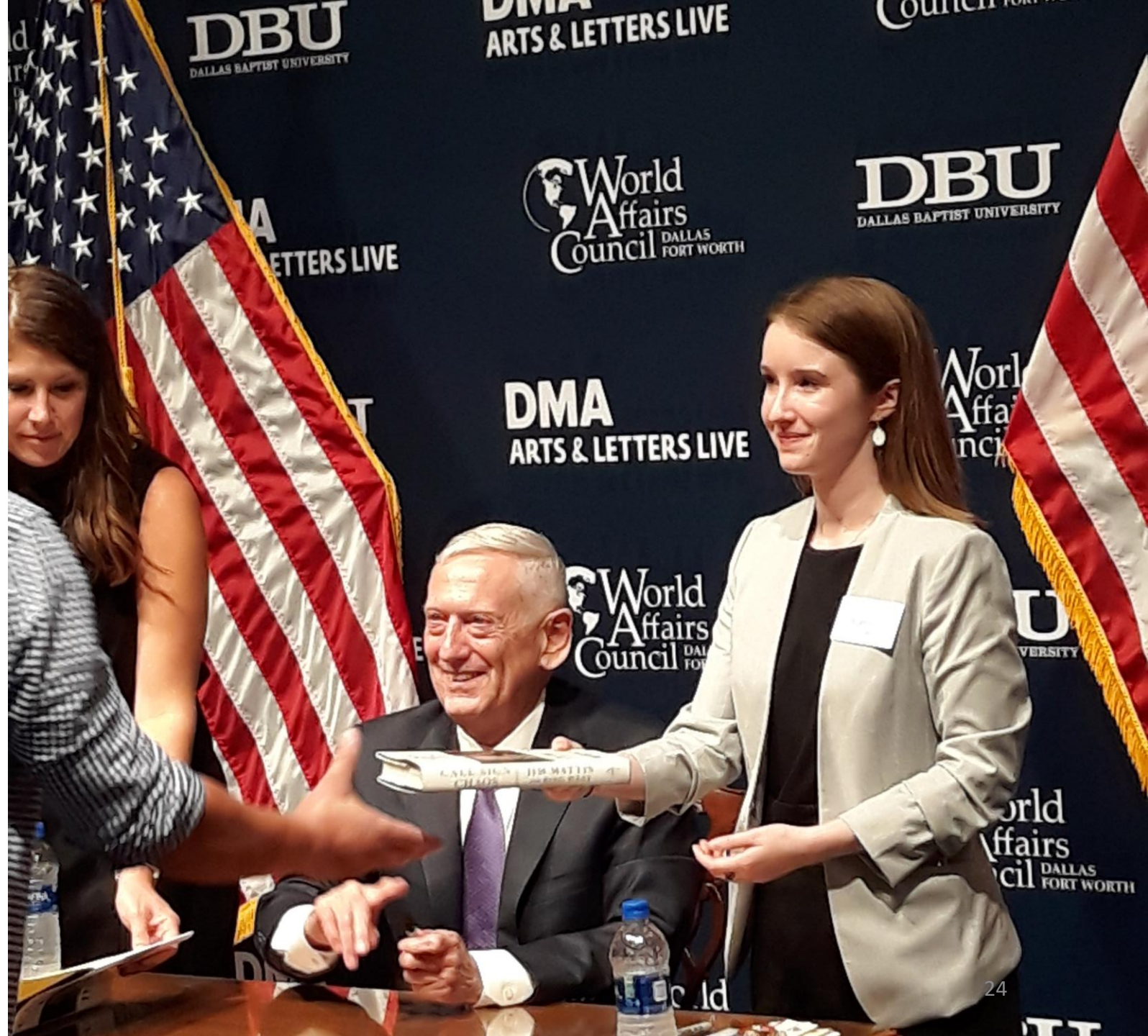

Procurement

- Prime / Subcontracts
- Administration – Lawyer – U.S Trained / Worked in that Country
- Awareness – Buying Local – Quality, Delivery Promises, Buyer be Ware
- Export / Import Restrictions and Delays
 - Imports Sit in Customs for 1 month – no urgency
 - Courier to Bring in Urgent Items - Immediately Clears Customs
 - Field Procurement Check Book – Duty Paid on the Spot

Cultural

- Tomorrow Does Not Mean What You Think It Means
- Accidentally Killing a King Cobra Snake – Worshiped As a god
- Eye Wash Stations and Ablutions
- Argument Between Two Tribes / Two Towns – Blocked Access Road

Cultural

- Local Tribal – Chiefs / Kings – Teenage Boys with Gold Ankle Bracelet
- Engineers – Scratching Paint on a Parked Car
- “How Does It Feel Being A Native in Your Own Country and Cannot Speak Their Language?”
- When task is completed, engineer folds their hands at their desk and waits for their supervisor to come by and observe them. Sometimes several days.





3rd World / Developing → 1st World

- Pilot Friends

- Fastening Seat Belts – Show – Unknown Concept
- Where do Parents have children Go when on an airplane?
- Lack of Experiences to Develop Wisdom
- Acquiescence to Expat Captain
- Fear – Instructors Orders – Watch the Fuel Balance Between Wings
- “Gossip Chain” – Each one Teach one – No Standards – F.O. to Jump Seat Trainee. Native Language. No Quality Control. Degradation of Instruction.

3rd World / Developing → 1st World (con't)

- Seen these on the construction site and in Engineering.
- Pressure Safety Valve – Offshore Platform – Separation Vessel – 500 psig
 - Government Has Edict – Do Not Pollute the Ocean
 - No PSV – Avoid Pollution
 - When A Vessel Overpressures – What Happens?
 - Finally – I am the Boss – You will Do as I Command
 - Engineer in his 40s – Adjunct at Local University Teaching Design
- B31.3 Process Piping Code – Hydrotest

Full Penetration Welds – Xray Inspection

Penetration

Throat thickness

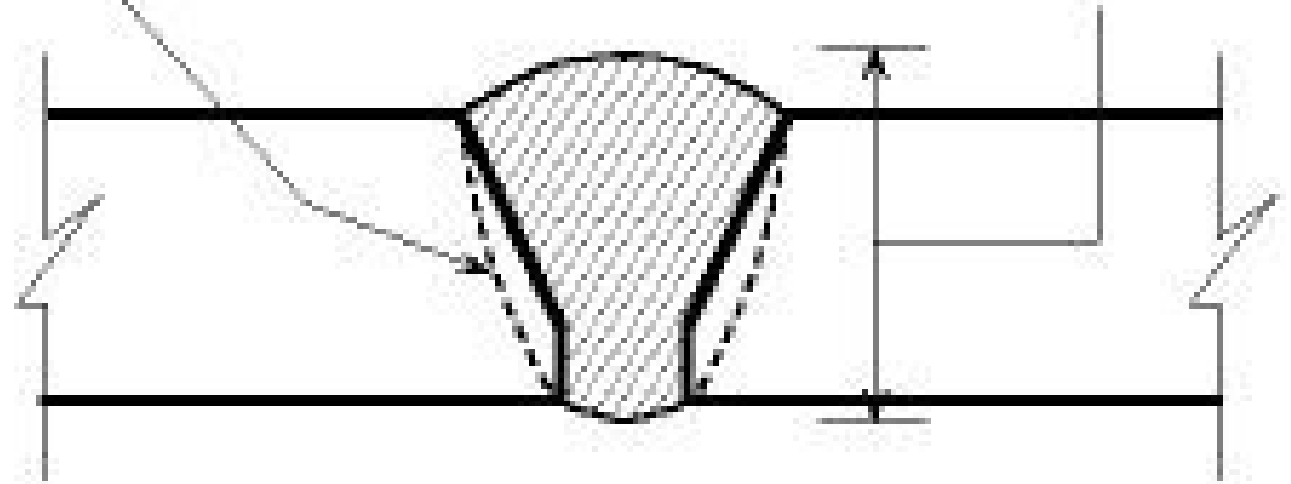

Figure 1 Butt weld with full penetration



Overall

Challenges, Risks, Frustrations

But

Great Rewards

Lifetime Friendships

Pride of Making a Difference