

The drawing and procedures were missing some things January 2022

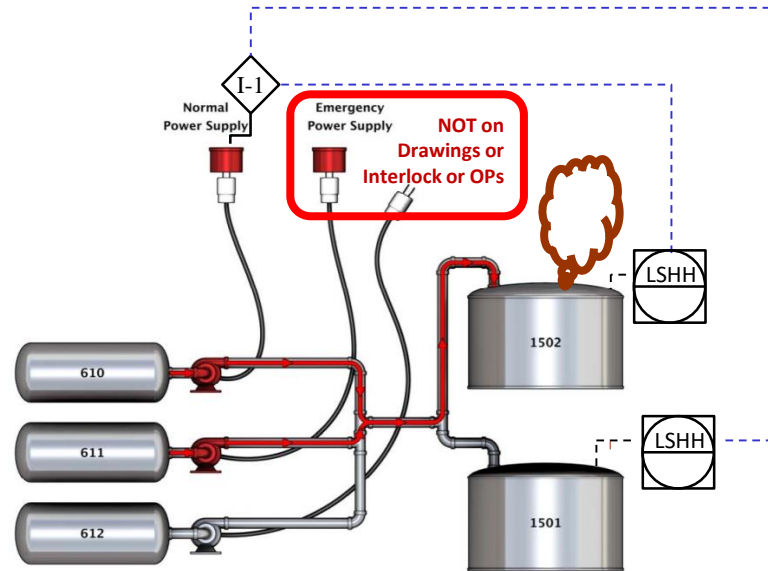

Fig. 1 Schematic of the oleum transfer system (see reference below)

On October 11, 2008, an overfill of oleum (a solution of sulfur trioxide in sulfuric acid) put a cloud of toxic and corrosive SO₃/H₂SO₄ mist across three towns in Pennsylvania. About 2500 people had to evacuate or shelter-in-place. Fortunately, no serious injuries occurred.

Originally, the facility was built with one power supply and three plug-in pumps. This prevented more than one pump being used at a time. To prevent an overfill, this power supply was interlocked to stop the pump on a High-High (HiHi) level in either tank 1501 or 1502. However, in the 1980's, a "temporary" emergency power supply was added after several power outages in the main/normal system. This emergency system was never added to the Piping and Instrumentation Diagrams (P&IDs), nor to the operating procedures. Importantly, it was NOT controlled by the HiHi level interlock.

On the day of the overflow, an operator was called in and began to pump oleum from Tank 610 to Tank 1502. To save time, he also began a transfer from Tank 611 to Tank 1502 by plugging another pump into the emergency power supply. This practice had been passed from operator to operator for many years, but it was not documented nor managed within the Process Safety Program. The HiHi Level switch was unable to stop the transfer from tank 611 and tank 1502 overfilled, releasing oleum.

Reference: <https://www.csb.gov/indspec-chemical-corporation-oleum-release/>

Did You Know?

- The plant had been running for many years before process safety regulations required accurate P&IDs, or operating procedures. Management of Change (MOC) was not used as rigorously as it is today.
- If your process was built before process safety regulations came into effect, you may have similar error traps lurking about.
- Operating Procedures must be up to date and must be followed exactly. Errors in procedures should be corrected.
- Operating Procedures should be well written and describe the process steps in a safe manner, to protect you, your company, and the community.
- Hazards of overfill were discussed in two Process Hazard Analysis (PHA) studies before the incident occurred. Credit was taken for the HiHi level interlock. It appears the operators never mentioned the "emergency power supply". It wasn't marked on the drawings, nor mentioned in the operating procedures which hid this weakness from the hazard review teams.
- All changes that can affect the process – including temporary power supplies – need to go through MOC.
- Safety interlocks should not be used to routinely stop the filling of a tank. The operating procedures should identify the normal point to stop filling.

What Can You Do?

- During Process Hazards Analysis (PHA) meetings, look carefully at the drawings. If they don't match what is in the field or if something is missing, point that out.
- All "undocumented practices" need to be pointed out to the supervisor. These practices must be written down, checked, and approved.
- Follow your procedures. If they aren't complete – or don't match your current practices – get someone to review and correct them.
- Beware of minor changes to the process. These should go through the Management of Change (MOC) procedure.

Drawings and procedures need to be accurate, up-to-date, & followed!