

What's the Price of Steam?

ROBIN SMITH

CENTRE FOR PROCESS INTEGRATION,
UNIV. OF MANCHESTER

PETAR VARBANOV

TECHNICAL UNIVERSITY OF BERLIN

Realistic steam prices are necessary for the efficient operation of a chemical production site, both to allocate realistic costs to the different businesses on the site and to provide a true economic incentive for energy conservation.

The basic problem with the question “What is the price of steam?” is that it is largely a meaningless question. Unless steam is purchased from a third party according to some contract price, steam does not have a cost. Purchased fuel has a cost. Purchased power has a cost. Power exported from the site and sold has a value. Water and chemicals purchased for steam generation have costs. Labor and maintenance also have costs.

However, steam does not have a direct cost. It is simply an intermediary between the primary costs (*e.g.*, fuel) and the end users. Yet somehow we need to distribute to the businesses on the site the primary costs that result from their use of steam.

Modeling and optimization of utility systems

To analyze a utility system, it is first necessary to develop a simulation model (*I*), which can be done using commercially available software. The simulation model should allow part-load performance of the steam system components. It should provide a simulation of the complete material and energy balance around the steam system, and be capable of predicting the fuel, power generation, water requirements, etc. for any condition of the steam system. The model must take into account the operating constraints around the system, for example with respect to steam flows from steam generation devices and steam flows through steam turbines.

Once such a simulation model has been developed, it can be subjected to optimization. The important degrees of freedom in utility systems are:

Multiple steam generation devices. Each steam generation device within the utility system can use a different fuel or a different combination of fuels, and usually has its own efficiency that varies with the steam load. The firing in the gas turbine combustor

and supplementary firing are two independent degrees of freedom. Steam can also be generated from waste heat within a process. However, such in-process steam generation will be assumed here to be fixed according to the operation of the process.

Multiple steam turbines. Generally, steam turbines have different efficiencies, depending on their size, design, age and maintenance. For a given turbine, the efficiency varies with load. Hence, if there are two or more steam paths through the utility system via different steam turbines connecting two steam headers, this introduces additional degrees of freedom for internal flow distribution.

Letdown stations. Steam can be transferred between headers via letdown stations rather than steam turbines. Usually, large letdown flows indicate a missed opportunity for power generation. However, in some instances, letdown station flows can be exploited to bypass constraints in the steam turbine flows at one level in order to exploit the letdown flow at a lower level for power generation. Also, if the letdown station involves de-superheating by injection of boiler feedwater (BFW), the temperature at the exit of de-superheating is an additional degree of freedom.

Condensing turbines. Condensing steam turbines provide utility systems with additional degrees of freedom, generating extra power, but rejecting heat to atmosphere.

Vents. As with condensing steam turbines, venting steam from low-pressure headers also provides additional degrees of freedom to increase power generation. While this might seem a waste of steam, if there is a significant price differential between the price of power and heat, it can be economic. Again, heat is rejected to the atmosphere.

The optimization model for existing utility systems can be

Heat Transfer

used to make continuous and discrete decisions. Discrete decisions relate to the operational status (on/off) of the devices. For example, it might be possible to switch between a steam turbine or an electric motor on a particular drive.

The energy balances of the system elements include nonlinear terms that result in a nonlinear optimization, with the potential to bring all of the associated problems of local optima (1). Fortunately, this difficulty can be overcome by fixing both the temperature and the pressure of the steam mains during the optimization to produce a linear optimization model, which is straightforward to solve (1). This is followed by a rigorous simulation after each optimization step. The linear optimization is repeated, followed again by rigorous simulation, and so on, until convergence is achieved. This procedure usually requires no more than four or five iterations to reach convergence (1).

Using the optimization model to set steam prices for fixed loads

Consider first the case where the steam heat loads for the processes on a site are fixed and the objective is to calculate the cost of the steam for the allocation of costs to the processes and businesses on the site. Establishing the true steam costs for an existing steam system requires a model that reflects, as much as possible, the performance of the existing equipment and the constraints in the existing equipment and steam network. The model should also include the existing steam heating demands for the various processes.

This model should first be optimized, as previously described. The cost to generate the steam in the utility boilers can be calculated from the optimized model. This will mainly be the cost of

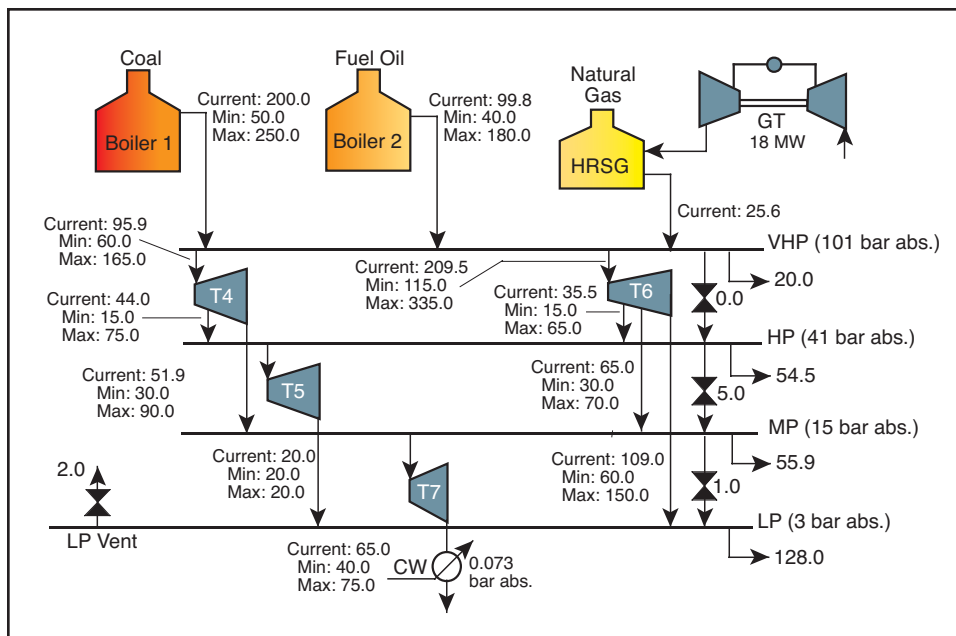

Figure 1. A typical site utility system for a CPI facility.

fuel, but could include other costs as well. Having calculated the cost of the highest-pressure steam, the model will also provide the amount of power generated by expansion of the highest-pressure steam to the next-highest pressure. The value of this power can then be subtracted from the cost of generating the highest-pressure steam in the utility boilers to give the cost of the next-highest pressure steam. The calculation is repeated for the next lower pressure level, and so on. Thus, the cost of each steam level is the cost of the next highest level minus the value of the power generated from the expansion from the next highest level. This model incorporates the performance data and constraints associated with an actual system, rather than an idealized model.

In extreme cases, this approach to costing steam might lead to steam at low pressure having a negative cost. This can happen if fuel is relatively cheap and power is relatively expensive. This is not a fundamental problem, as it reflects the true economics. The site utility system is benefiting from the availability of a heat sink for the low-pressure steam. However, it should be emphasized that if the low-pressure steam has a negative cost, this does

Table 1. Fuel data for Example 1.

	Fuel 1 Coal	Fuel 2 Fuel Oil	Fuel 3 Natural Gas
Normal Heating Value, kJ/kg	28,000	40,000	52,000
Price	\$0.065/kg \$65.0/t \$0.0084/kWh	\$0.12/kg \$120.0/t \$0.0108/kWh	\$0.22/kg \$220.0/t \$0.0152/kWh

Table 2. Site configuration data for Example 1.

Ambient Temperature	25°C
BFW Temperature	110°C
Cooling Water Temperature	25°C
Site Power Demand	68.0 MW
Minimum Power Import	0 MW
Maximum Power Import	50.0 MW
Minimum Power Export	0 MW
Maximum Power Export	50.0 MW
Power Price	\$0.05/kWh
Cooling Water Price	\$0.005/kWh

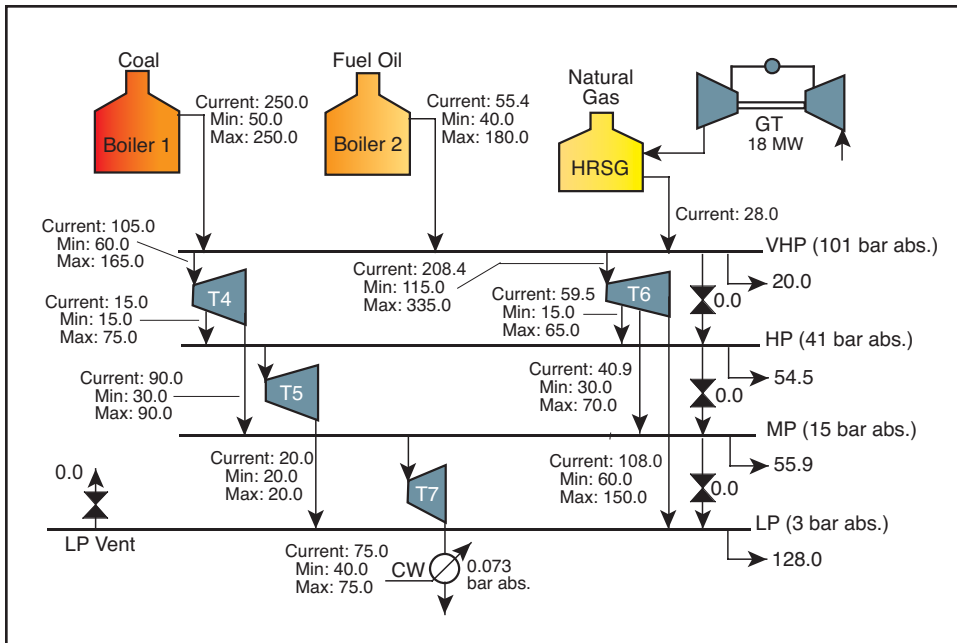

■ Figure 2. Typical site utility system after optimization.

not necessarily mean that it is economic to increase low-pressure steam consumption significantly. As will be seen later, the cost of steam is likely to change as its consumption changes.

It should also be noted that variation in electricity costs will change the optimization and therefore the steam costs. For this situation, an average can be taken according to the relative duration of the costs.

Example 1: Steam prices for fixed steam loads

Consider now the steam prices for the existing utility system in Figure 1 when the loads on the various steam headers are fixed. The fuels in use are summarized in Table 1 and the site configuration data are given in Table 2. There is a demand for very-high-pressure (VHP) steam from various processes on the site to drive steam turbines on fixed drives with condensed exhaust. There are also demands for high-pressure (HP), medium-pressure (MP) and low-pressure (LP) steam for process heating. In addition, steam is expanded through various steam turbines.

Figure 2 shows the same utility system after optimization. The steam cost can now be calculated for the base case and the optimized case. Table 3 presents the costs of the various steam levels based on the fuel value of the enthalpy difference between the steam mains, an isentropic efficiency steam turbine model (assuming a typical 85% isentropic efficiency and 95% machine efficiency) and the full simulation model.

Table 3 shows that the cost model based on the fuel value of the enthalpy difference between steam mains significantly over-predicts the prices of lower-pressure steam levels. On the other hand, the

isentropic efficiency model predicts costs that are too low for lower-pressure steam levels. (Of course, the results for the isentropic efficiency model depend on the assumption for the isentropic efficiency.) It is also clear that there are significant differences between the costs calculated for the base case and the optimized case. Finally, the cost of the lowest-pressure steam is negative when based either on the isentropic efficiency model or the simulation model. The most appropriate costs are those from the right-hand column of Table 3.

Steam prices for changing loads

Consider now the case where the steam price needs to be determined for a change in process heat load, for example for the retrofit of a heat exchanger network for increased heat recovery. Alternatively, a project might involve an increase in heat demand as a result of commissioning a new plant or expansion of an existing one.

The starting point is a model for the steam system, again optimizing for the existing steam heating loads. It might be suspected that the steam cost calculated from the model for the existing steam loads can be used to provide steam costs for an increase or decrease for a given steam main. Unfortunately, this is not the case. The optimum settings for the steam system change once the loads for the steam mains change. Constraints on the existing equipment will also be encountered, and all of this needs to be accounted for.

Consider again Figure 2 showing the existing site utility system (2). Suppose that it is possible to reduce the HP steam demand. This could be done, for example, by improving the heat recovery within the processes that use HP steam.

But what is such a steam saving actually worth? The saving in steam from the HP mains means that it now does not need to

Table 3. Steam prices for fixed process steam loads for Example 1.

Steam Level	Price Based on Enthalpy Difference	Price Based on Ideal Steam Turbines		Price Based on Actual Steam Turbines	
		Base Case	Optimized	Base Case	Optimized
VHP	\$8.32/t	\$8.32/t	\$7.94/t	\$8.32/t	\$7.94/t
HP	\$7.78/t	\$5.17/t	\$4.78/t	\$5.78/t	\$5.32/t
MP	\$7.26/t	\$2.21/t	\$1.83/t	\$3.34/t	\$2.61/t
LP	\$6.54/t	-\$1.47/t	-\$1.86/t	\$0.17/t	-\$0.55/t

Heat Transfer

be expanded through steam turbines from the VHP level. This, in turn, means that there is a surplus of steam at the VHP level.

The first obvious action to take is to reduce the steam generation in the utility boilers and accept a saving in fuel costs as a result. Unfortunately, the saving in fuel costs would also be accompanied by an increase in power costs. This results from the reduction in the flow of steam through the steam turbines, and additional power would have to be imported (or export power decreased) to compensate. It is therefore not so straightforward to determine exactly what the cost benefits associated with a steam saving would be.

Another way to deal with the surplus of steam at the VHP level created by a steam saving would be to pass the heat through an alternative path, say to the condensing turbine. This would allow additional power to be generated, with a resulting cost benefit. In a complex utility system, the heat can flow through the utility system through many paths. The flow through different paths will have different cost implications.

In assessing the true cost benefits associated with a steam saving, the steam and power balance for the site utility system must be considered, together with the costs of fuel and power (or power credit if power is exported).

If steam is being generated, rather than used, then the same basic arguments apply. For example, suppose HP steam was being generated by a process into the HP main in Figure 2. The project to improve the heat recovery in this process might lead

to an increase in the HP generation. This leads to a surplus of HP steam, which in turn leads to a surplus of VHP steam. Then the same arguments apply as to what is the most efficient way to exploit the surplus of VHP steam.

The only way to reconcile the true cost implications of a reduction in steam demand created by an energy reduction project is to use the optimization techniques described earlier. An optimization model of the existing utility system must first be set up. Starting with the steam load on the main with the most expensive steam, this is gradually reduced and the utility system re-optimized at each setting of the steam load. The steam load can only be reduced to the point where the flowrate constraints are not violated.

The concept of steam marginal cost is used as an indicator in the analysis. It is defined as the change in utility system operating cost for unit change in steam demand for a given steam main (change in steam main balance) (3):

$$MP_{STEAM} = \Delta Cost / \Delta m_{STEAM}$$

where MP_{STEAM} = marginal price of steam, $\Delta Cost$ = change in cost and Δm_{STEAM} = change in steam flowrate.

It is important to emphasize that the change in the operating cost is taken between the optimum operation before the steam demand change and the optimum operation after the steam demand change for the current step.

Approaches to Steam Pricing: What Not to Do

A common approach to pricing steam starts with first calculating the cost for the generation of high-pressure steam in the utility boilers or heat-recovery steam generators (HSRGs) associated with the gas turbines. This is usually dominated by the cost of fuel. Other costs include those for auxiliary steam and power required for steam generation, water and treatment chemicals, labor, and so on. The cost of the fuel could be used as a first approximation of the cost of the high-pressure steam generation.

One approach to setting the price of lower-pressure steam is based on the enthalpy difference between the high- and low-pressure steam. The fuel value of the difference in enthalpy between two levels is calculated and subtracted from the price of the high-pressure steam. If a mix of fuels is being used, then a mean fuel cost weighted according to the calorific value of the fuels can be used.

While this sounds reasonable, it is completely inappropriate for all but the smallest utility systems, because it does not recognize the potential for the high-pressure steam to generate power by expansion in steam turbines. Estimating the potential for power generation from steam turbines by expansion between two different steam pressures is not difficult. Starting from the highest-pressure steam cost, if the pressure of the next-lowest steam level is fixed, then the amount of power that can be generated by expansion can be estimated based on an isentropic

efficiency model (3). Knowing the amount of power that can be extracted allows the value of the power to be estimated, and this can be subtracted from the price of the high-pressure utility steam to obtain the price of the lower-pressure steam. This seems to be more logical for utility systems with power generation in steam turbines.

Unfortunately, even this approach has a number of shortcomings. First, it assumes a single steam turbine in each expansion. There will usually be a number of turbines between each two mains.

Second, the efficiency of power generation is assumed to be fixed. In practice, the efficiency of steam turbines depends on the load. The load for some turbines can be varied, and for these turbines, the efficiency will vary according to the steam loads in various parts of the system. Other turbines, perhaps on direct drives, might have their loads (and hence their efficiencies) fixed.

Third, it does not account for the existing equipment for power generation, either from the point of view of its performance, or the constraints within the utility system. Some turbines are larger than others and are likely to be correspondingly more efficient. All turbines are constrained to operate between minimum and maximum steam flowrates. Complex turbines involving extraction or induction have constraints on the extraction or induction flowrates.

Steam demand for a given main can increase as a result of an increase in production rate or decrease in order to improve the energy efficiency of the site. The same approach can be used to deal with any context.

The first step is to optimize the operation of the utility system for the initial steam demands, as in Figures 1 and 2 (3). Next, the steam main with the highest steam marginal cost for the current steam demand is identified. The potential for decreasing the demand of this main is then determined by gradually decreasing the demand for that steam. At each step in the reduction, the whole utility system is re-optimized. If a constraint on decreased usage (or increased generation) is reached, or the marginal cost for the steam main changes significantly, the stepwise decrease in the steam demand (or increase in steam generation) is terminated. The procedure is then repeated for the steam main with the highest steam marginal cost for the new conditions until no further decrease in steam usage (or increased generation) is possible.

Example 2: Steam prices for changing steam loads

Consider again the utility system in Figures 1 and 2, but now the steam loads on the various steam headers are varied. The current process steam requirements will be examined for potential benefits of saving steam. Even for a relatively simple utility system such as this, there are many complex interactions to be explored in order to determine the true economic value of steam saved at any one of the pressure levels.

Figure 3 is a plot of steam marginal price versus the potential steam savings. It features six segments: three for HP steam savings and three MP segments. Saving LP steam has no value. Within each segment, there are slight marginal price variations, usually forming a stable trend, resulting from the nonlinearity of the steam turbine performance. The steps in the curve are

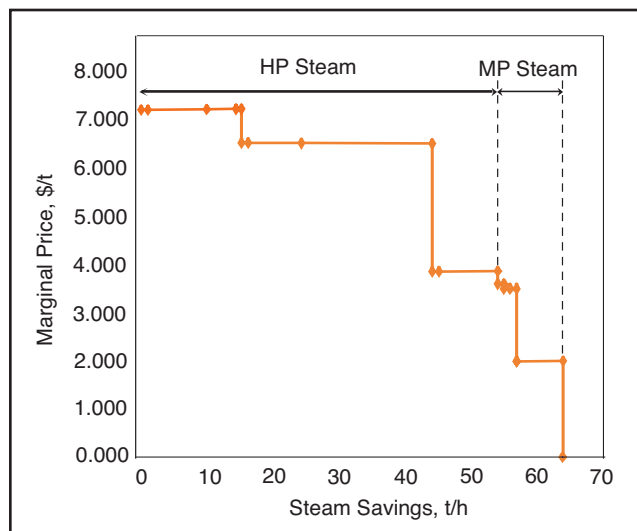

■ Figure 3. Marginal steam price versus potential steam savings when process steam loads change.

caused when, after optimization, further saving in steam along some path in the utility system is restricted by a constraint, typically a lower bound on a flowrate.

An important point to emphasize is that when the process steam load changes, the cost of a given level of steam can change, depending on the size of the change in steam load. The cost of steam in this situation not only depends on the costs of fuel and power, but also on the utility configuration, equipment performance and the constraints within the utility system.

Another important point to emphasize is that Figure 3 does not represent the feasibility of steam saving within the processes. The steam savings, as represented in Figure 3, might not be possible as far as the processes are concerned. Thus, the procedure should be interpreted as a kind of “what if?” analysis, *i.e.*, what would be the economic consequences of eventual steam savings in processes?

Figure 3 demonstrates that it is, in general, incorrect to attribute a single economic value for steam at a given level. Its value at a given level depends on how much is being consumed, as well as fuel cost, power cost, and so on. These marginal prices, together with the limits on steam saving, provide a strategy for energy conservation on the site without modification to the utility system. The step changes in the marginal price also provide indications for potential modifications to the utility system.

CEP

Literature Cited

1. Varbanov, P.S., *et al.*, “Modeling and Optimization of Utility Systems,” *Trans. IChemE*, **82A**, pp. 561–578 (2004).
2. Varbanov, P.S., *et al.*, “Top-Level Analysis of Site Utility Systems,” *Trans. IChemE*, **82A**, pp. 784–795 (2004).
3. Smith R., “Chemical Process Design and Integration,” Wiley, Hoboken, NJ (2005).

ROBIN SMITH is director of the Centre for Process Integration in the School of Chemical Engineering and Analytical Science at the Univ. of Manchester (P.O. Box 88, Manchester, M60 1QD, U.K.; Phone: 44-161-200-4382; Fax: 44-161-236-7439; E-mail: robin.smith@umist.ac.uk). He has extensive industrial experience with Rohm & Haas and ICI, and as a consultant on process integration projects. He has published widely in the field of process integration, and is the author of “Chemical Process Design and Integration” (Wiley). He holds bachelor’s, master’s and doctoral degrees in chemical engineering from the Univ. of Bradford in the U.K. He is a Fellow of the Royal Academy of Engineering, a Fellow of the Institution of Chemical Engineers in the U.K., a member of AIChE, and a Chartered Engineer. In 1992, he was awarded the IChemE’s Hanson Medal for his work on waste minimization.

PETAR VARBANOV is a researcher in the Dept. of Process Dynamics and Operation, Technical University of Berlin (Strasse des 17, Juni 135, KWT9, D-10623 Berlin, Germany; E-mail: varbanov@dynamik.fb10.TU-Berlin.de). He has worked in the field of energy efficiency, specializing in heat integration, at IChE — Bulgarian Academy of Sciences, and his professional interests include process modeling and optimization. He graduated from the Univ. of Chemical Technology and Metallurgy in Sofia, Bulgaria, with an MSc in chemical engineering, and studied for a PhD, in the field of optimization and synthesis of process utility systems, at the Univ. of Manchester.