

# Refinery Units and Streams

Jacobs Process PIT

Dave Collings

September 22, 2008

# Refinery Units and Streams

## Session Objectives

- Overall function of Oil Refinery
- Refining terminology, including Crude Oil and Product description
- Function of individual Refinery Units
- Interrelationship between Refinery Units
- Not a detailed course in Refining Technology

# Refinery Units and Streams

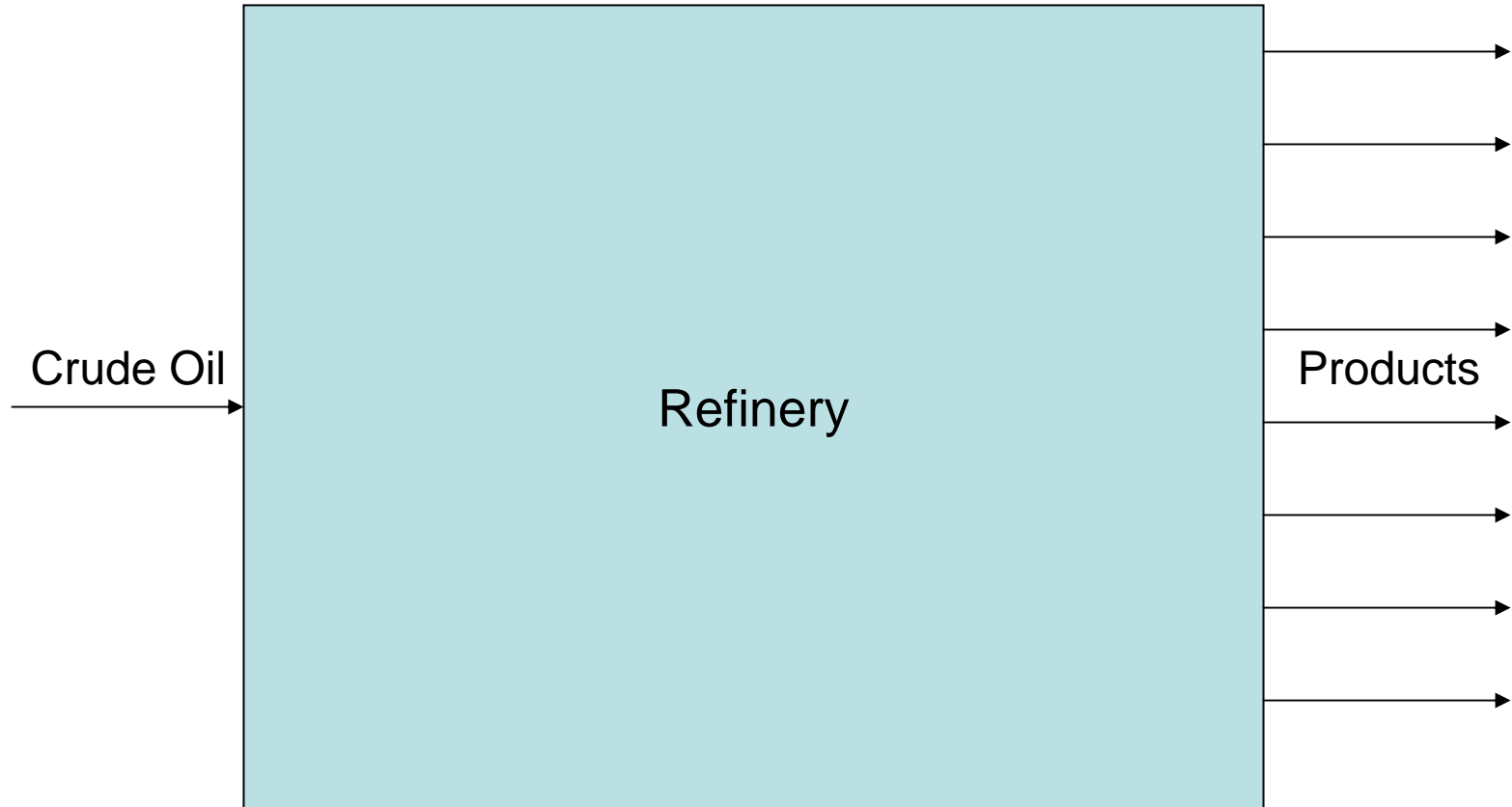

# Refinery Units and Streams

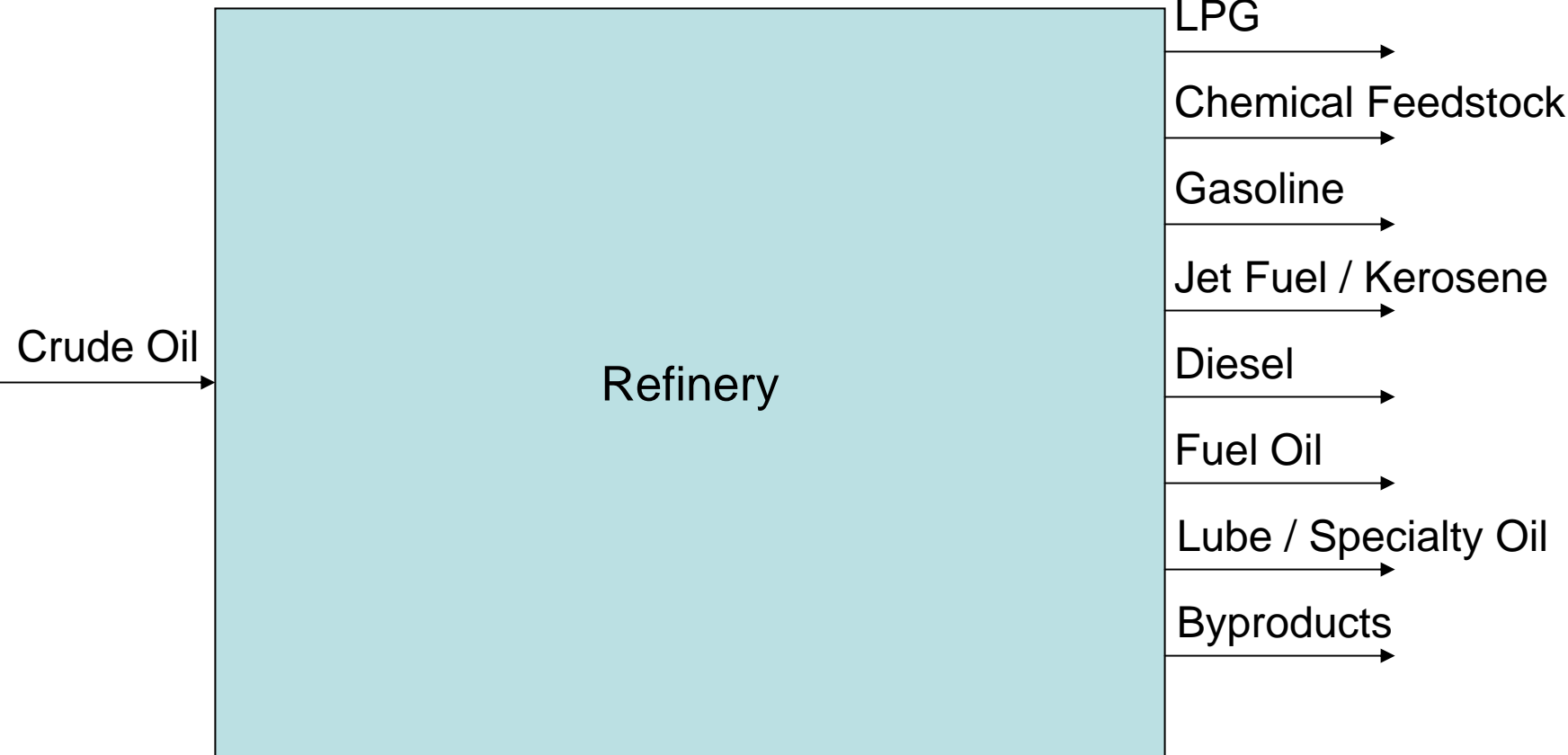

# Refinery Units and Streams

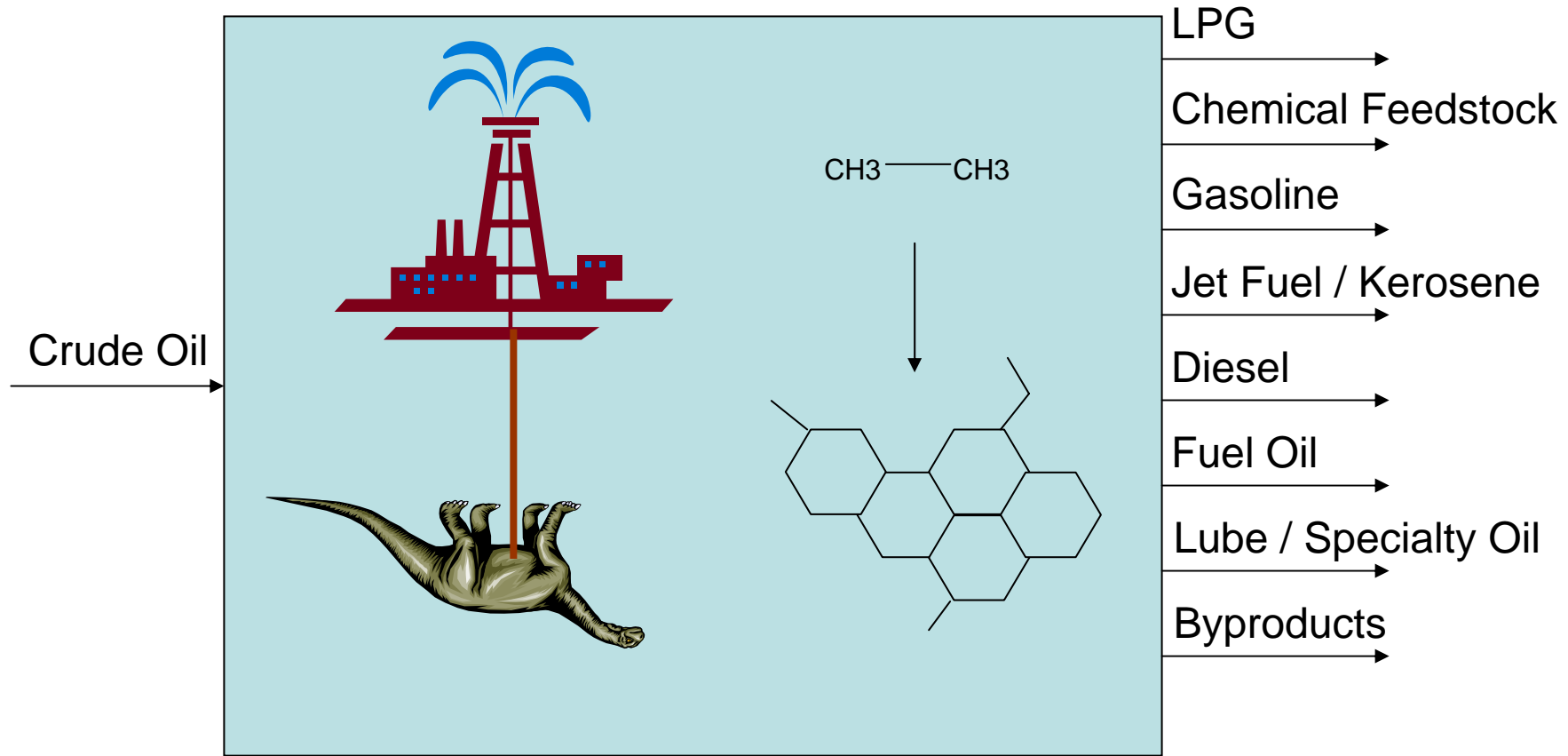

# Refinery Units and Streams

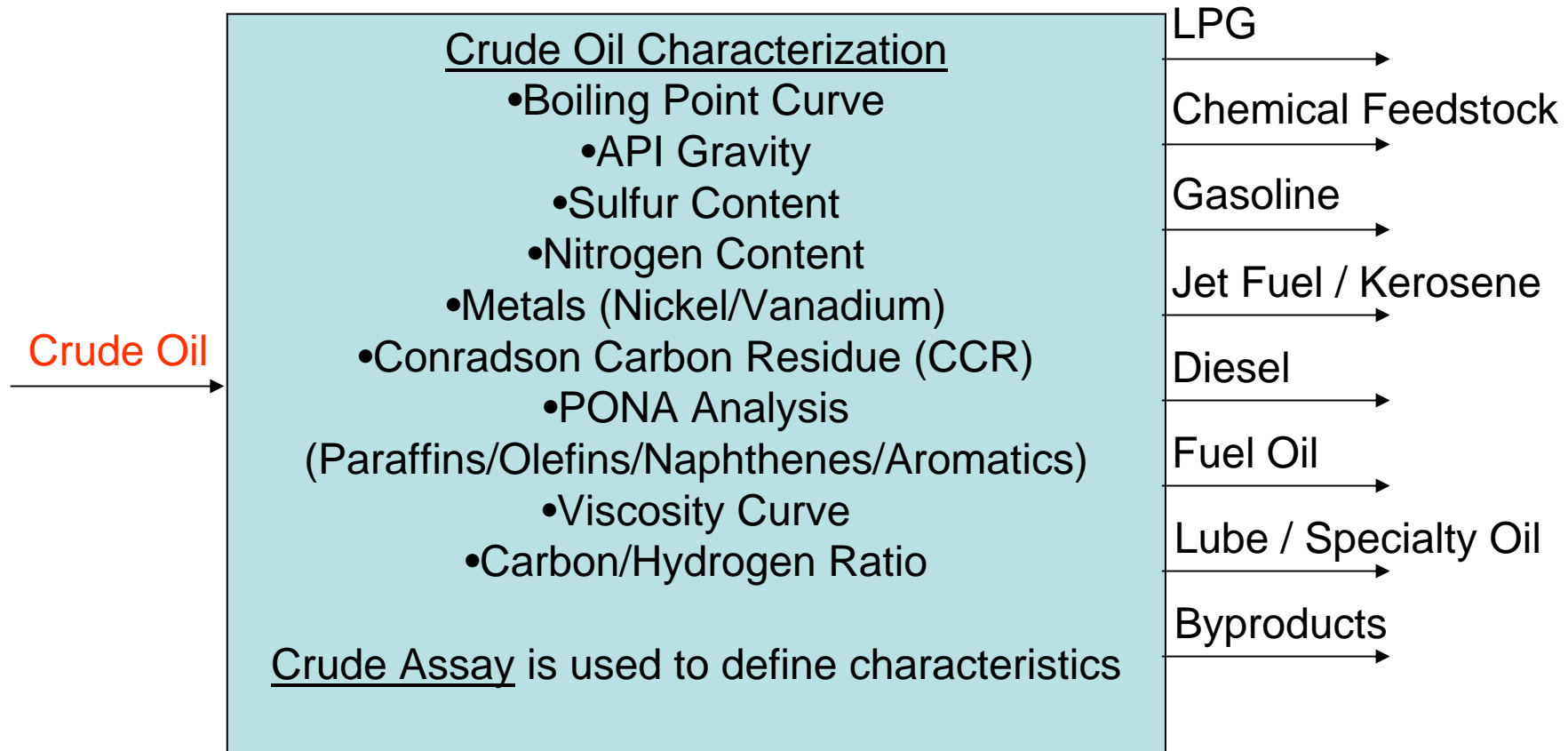



# Refinery Units and Streams

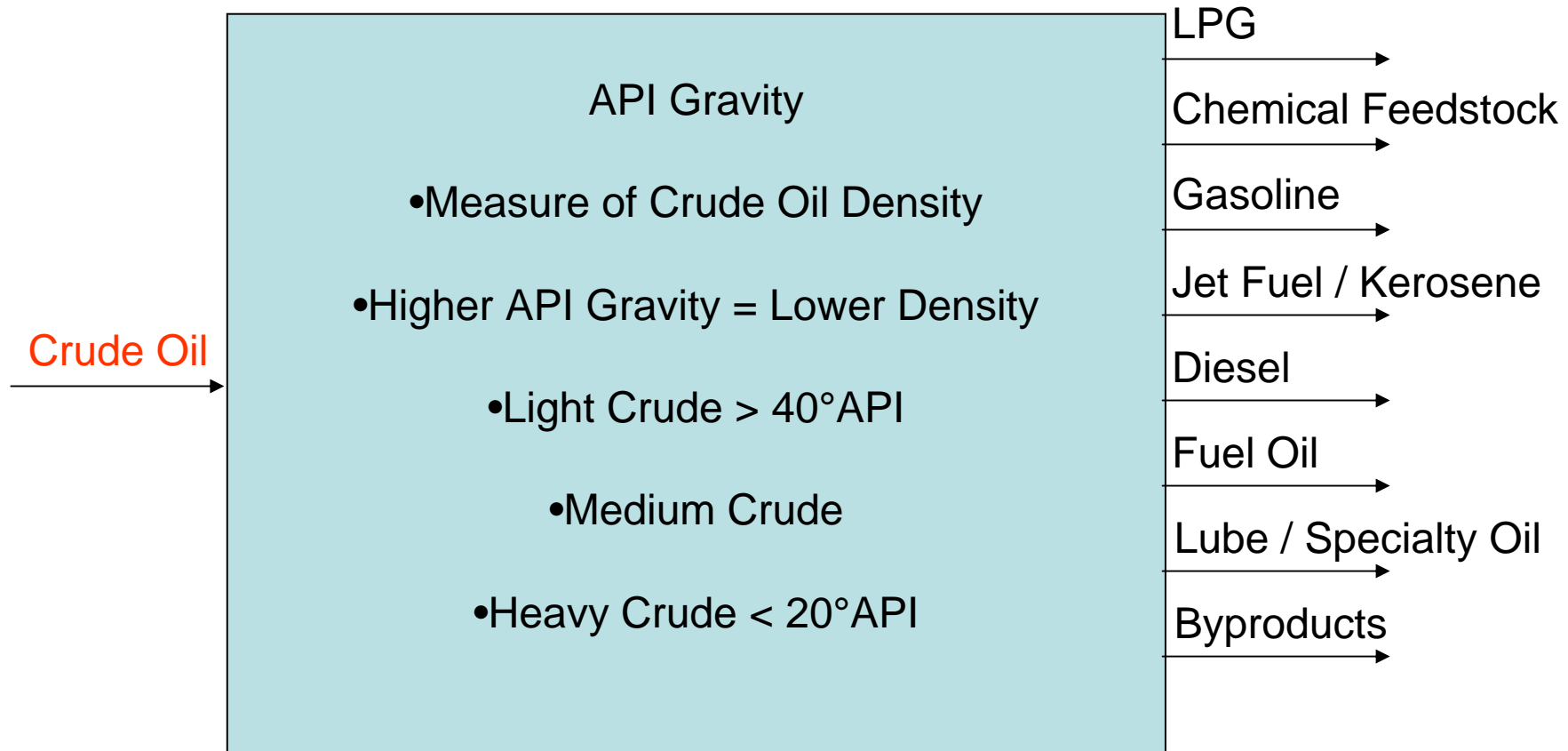

# Refinery Units and Streams

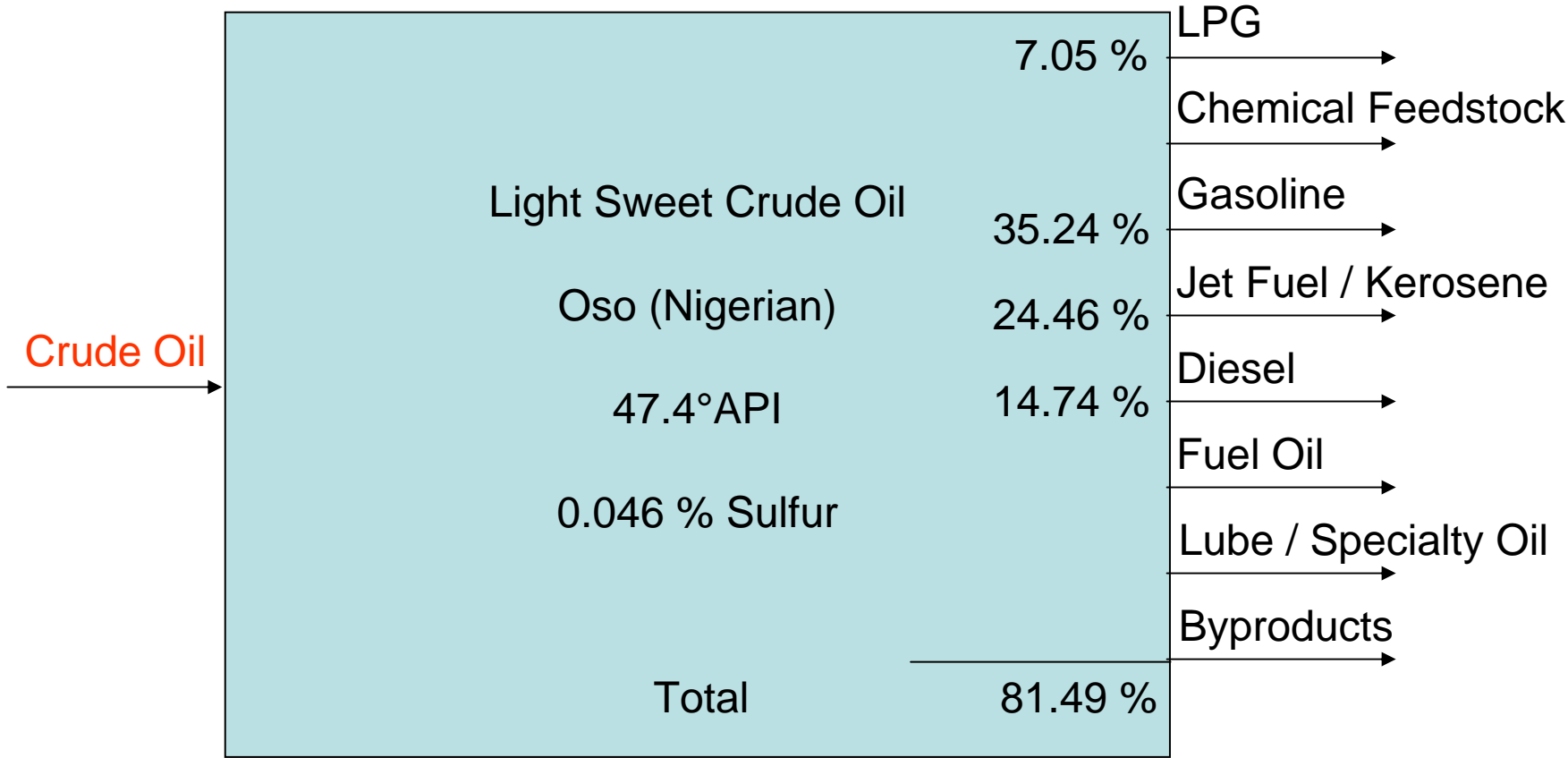

# Refinery Units and Streams

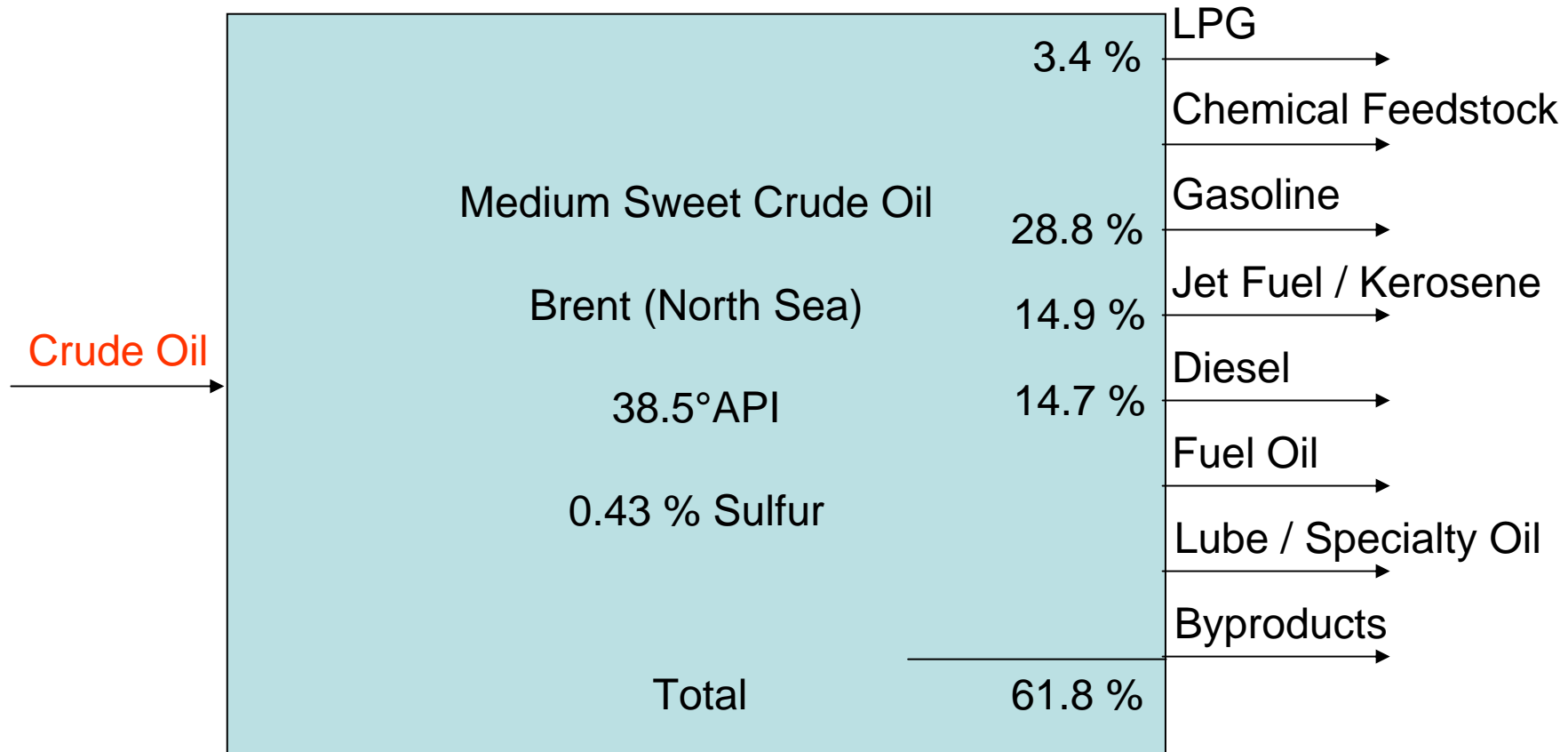

# Refinery Units and Streams

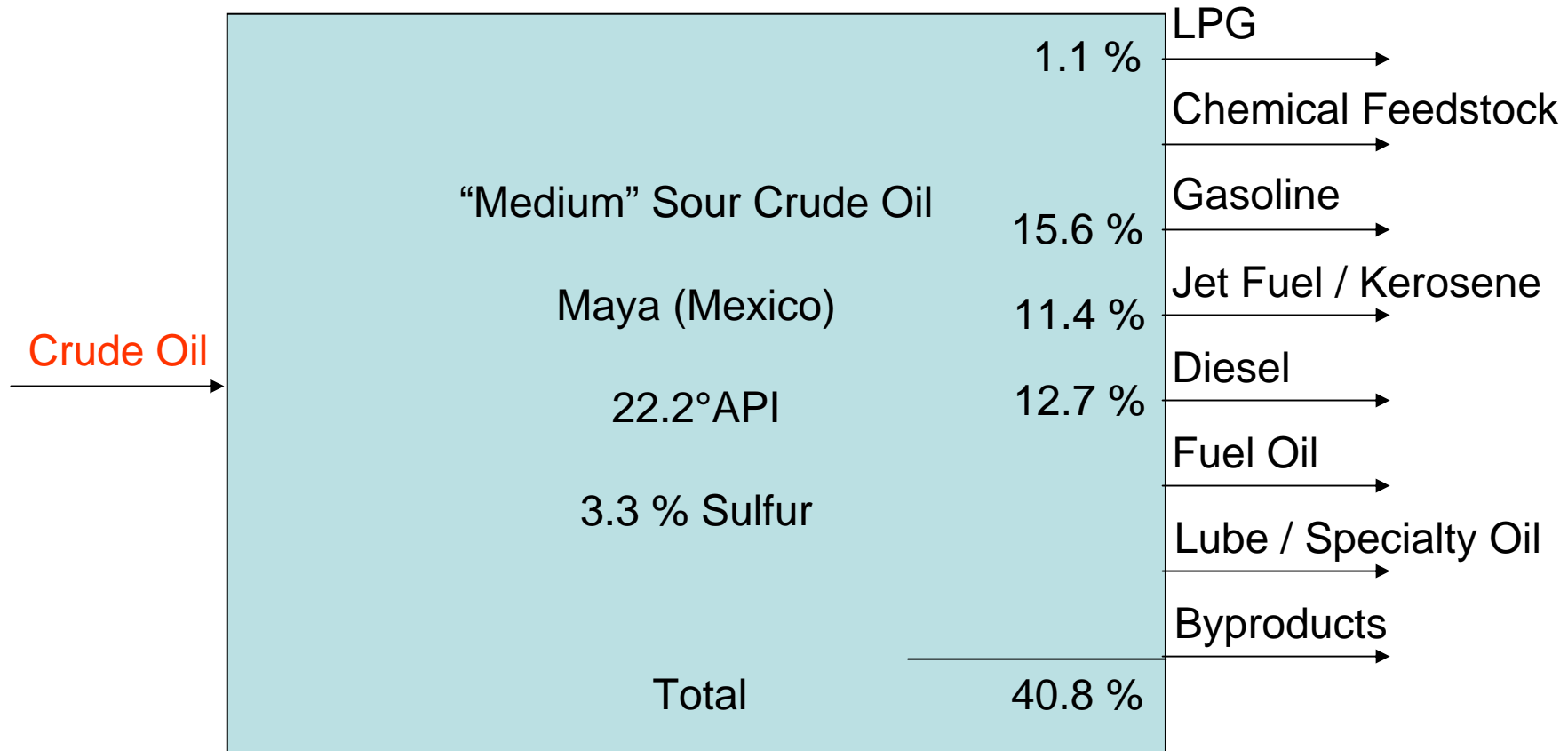

# Refinery Units and Streams

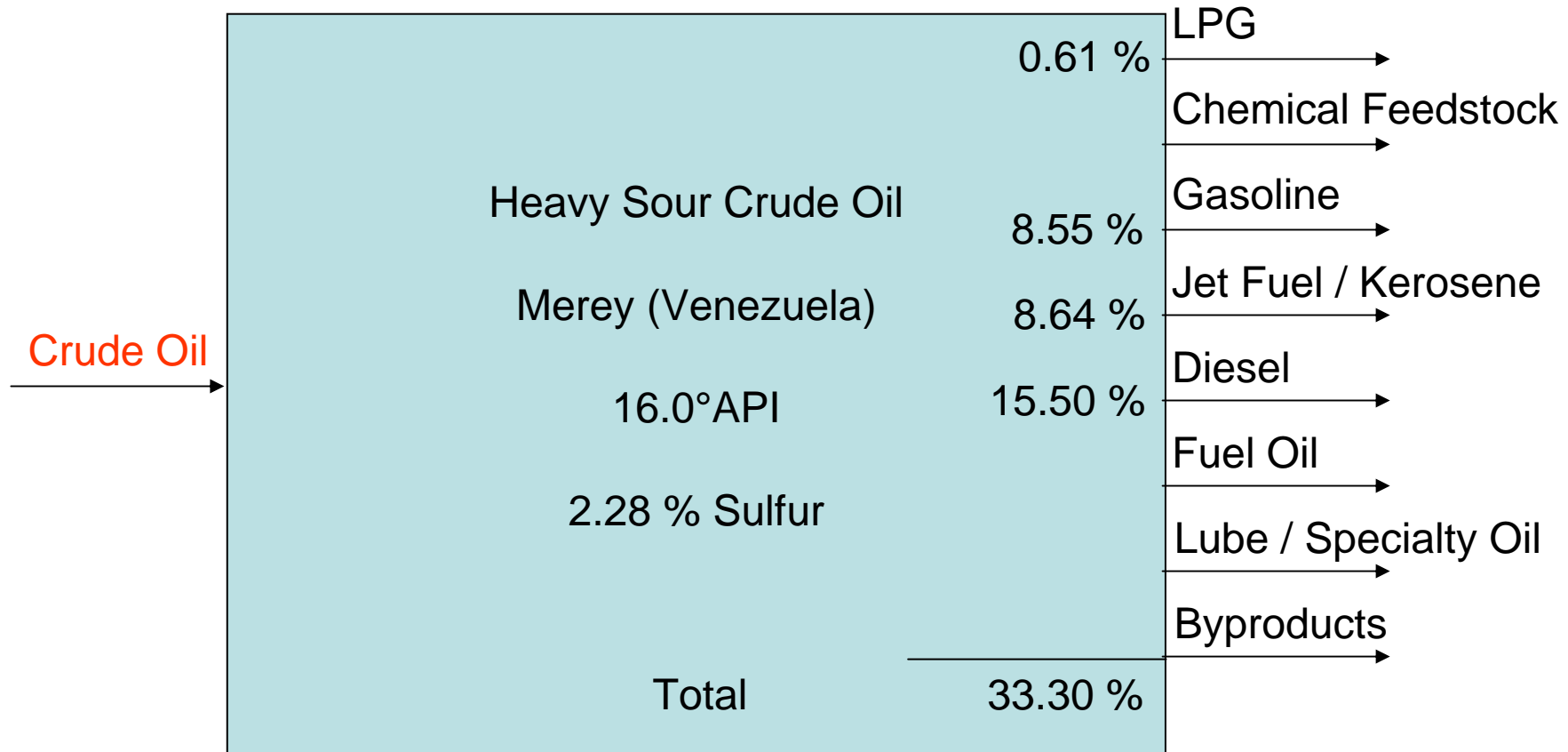

# Refinery Units and Streams

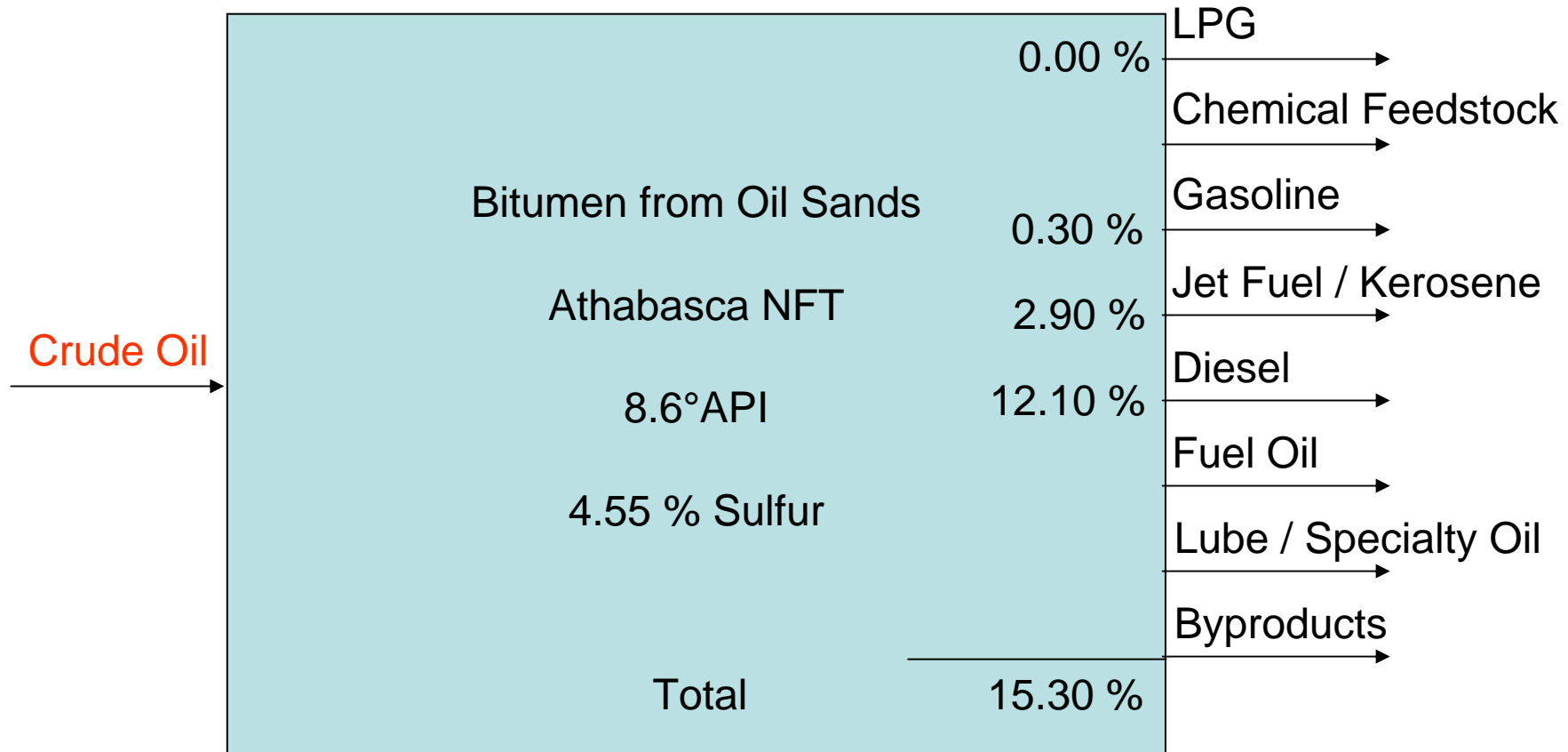

# Refinery Units and Streams

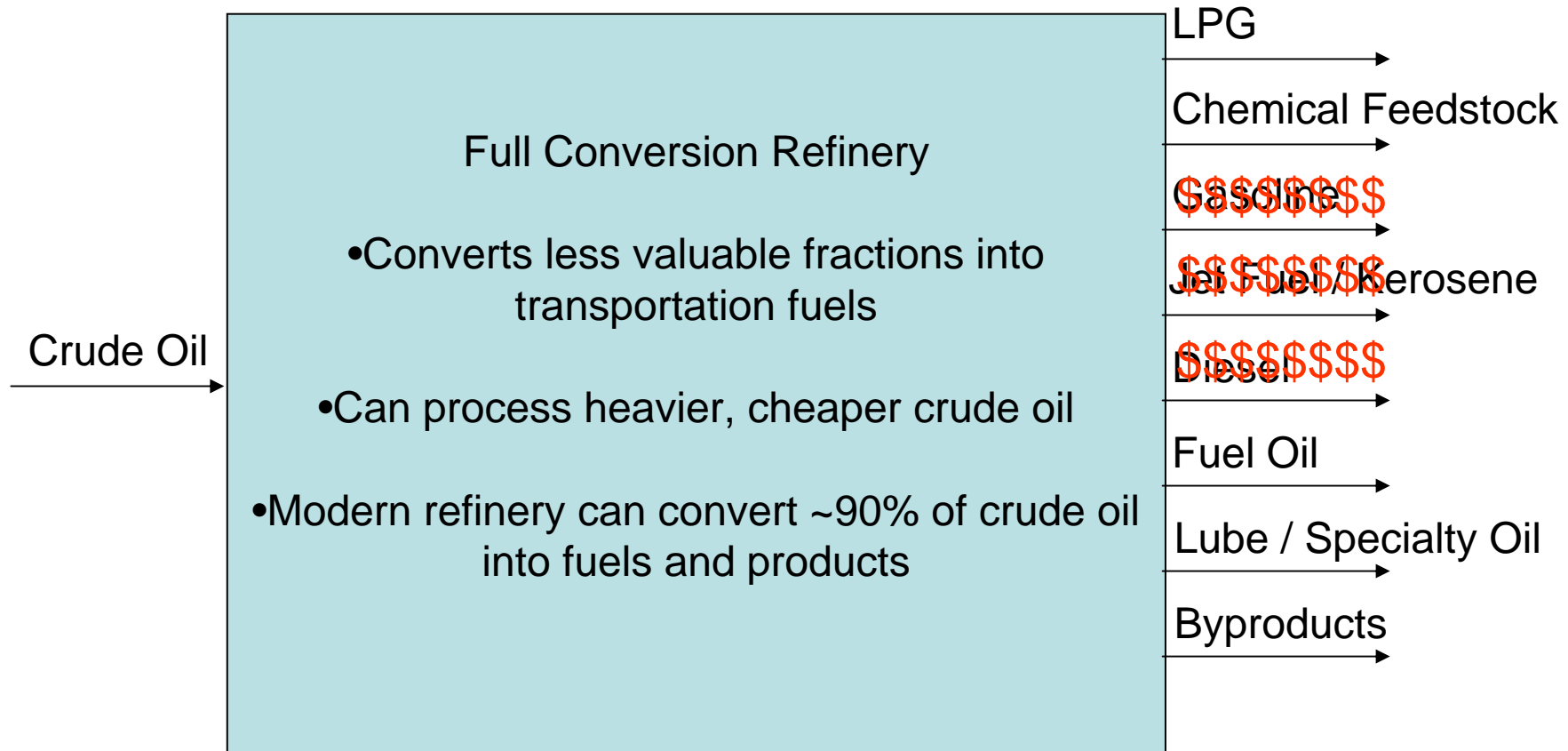

# Refinery Units and Streams

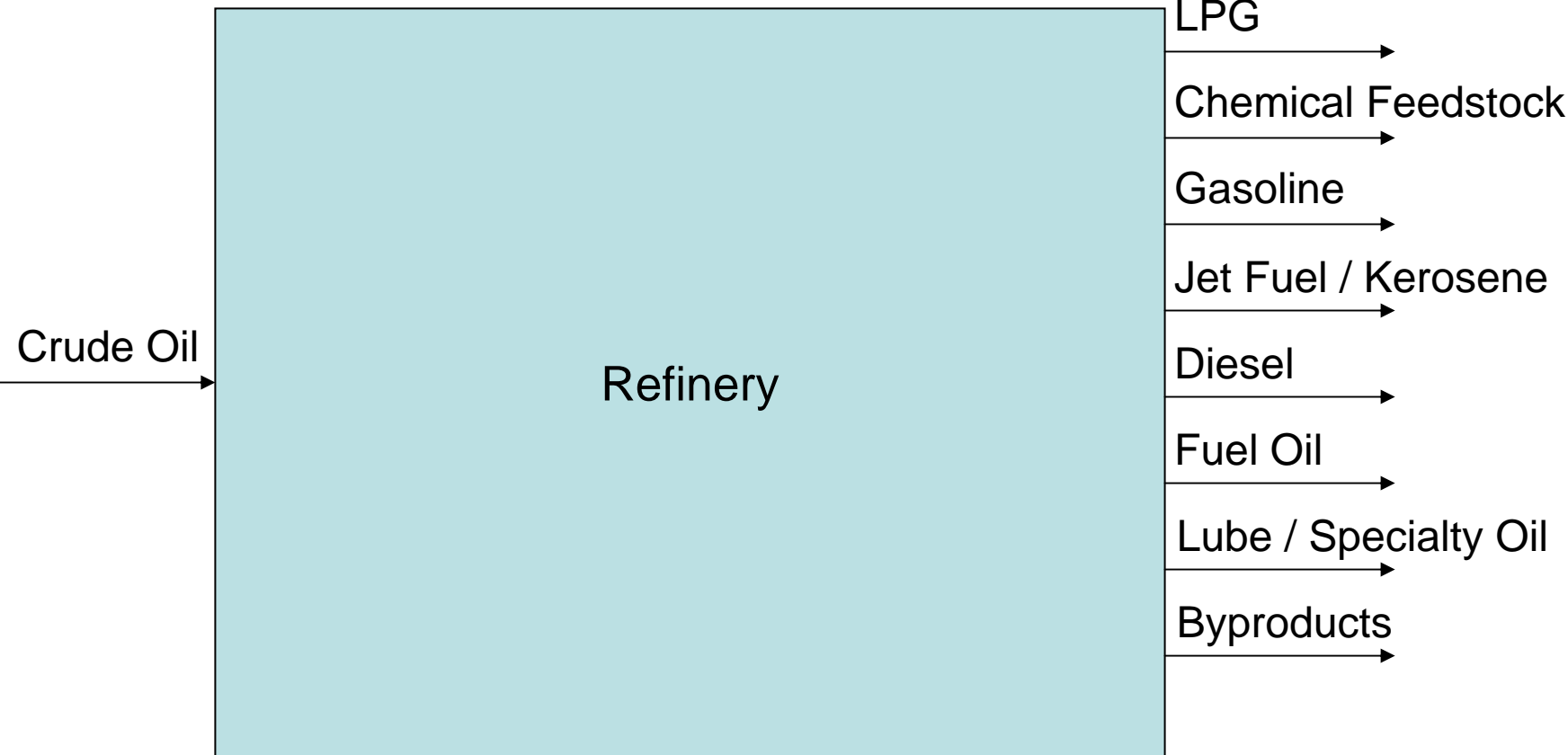

# Refinery Units and Streams

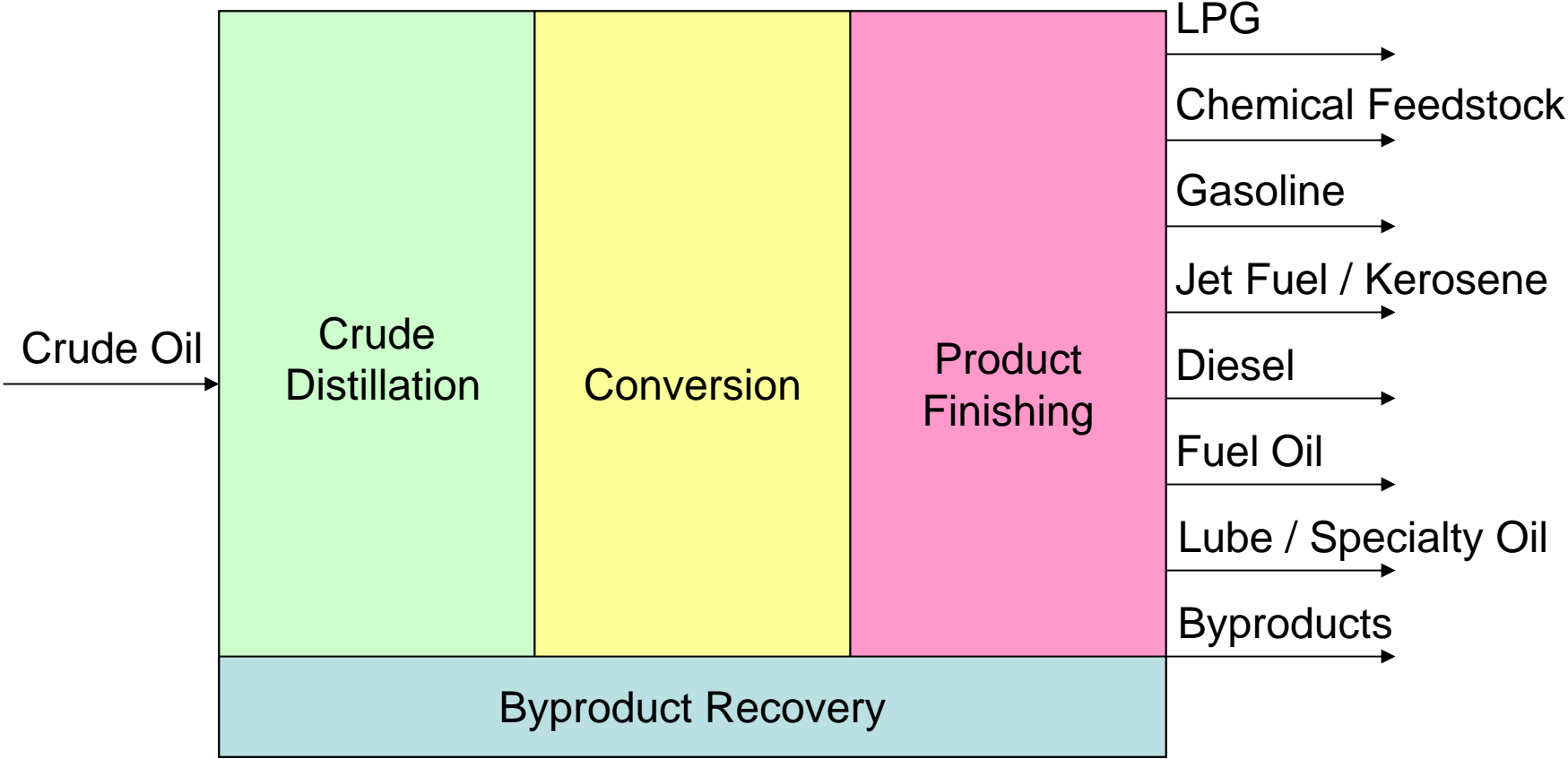

# Refinery Units and Streams

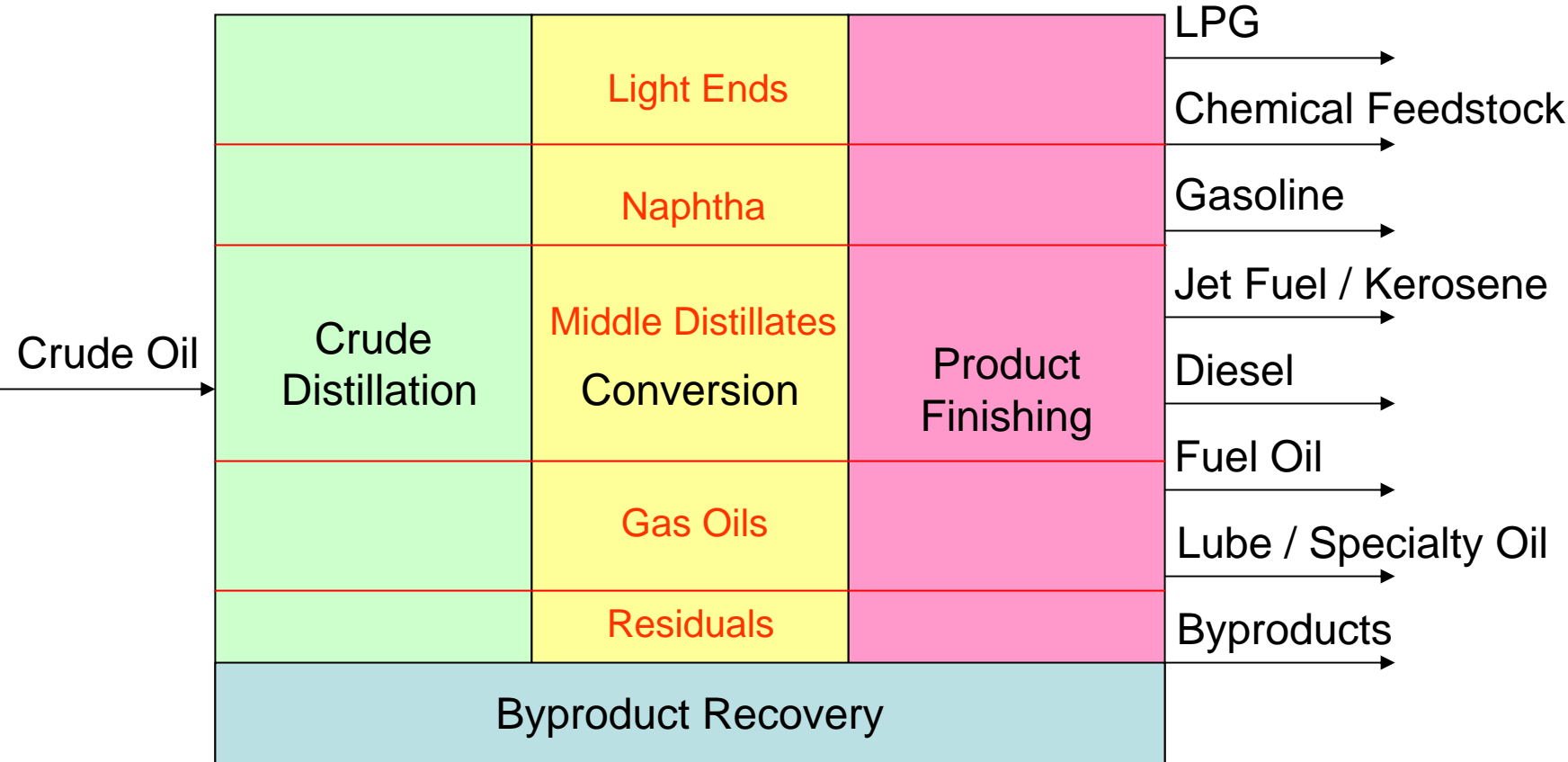

# Refinery Units and Streams

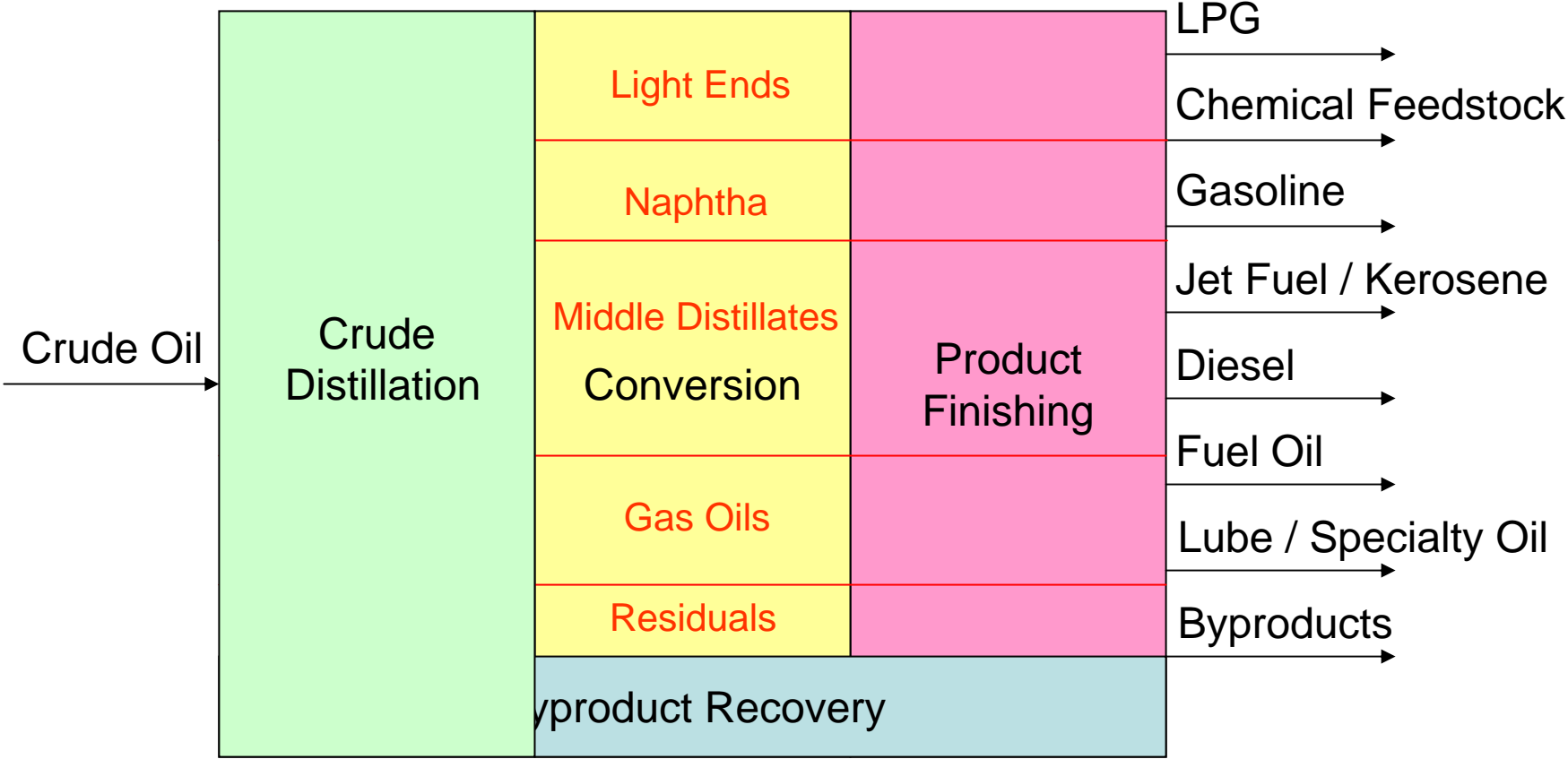

# Refinery Units and Streams

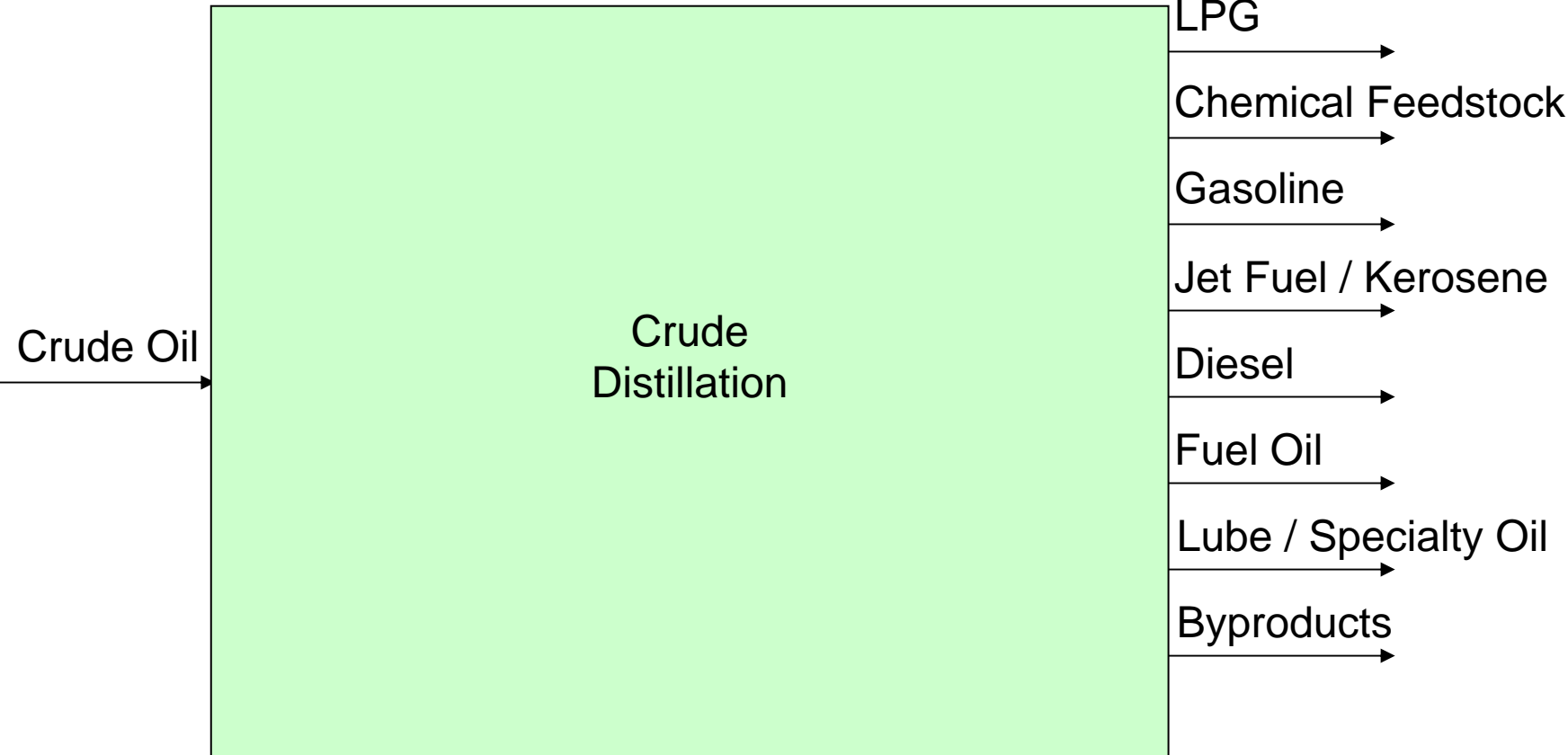

# Refinery Units and Streams

## Crude Distillation

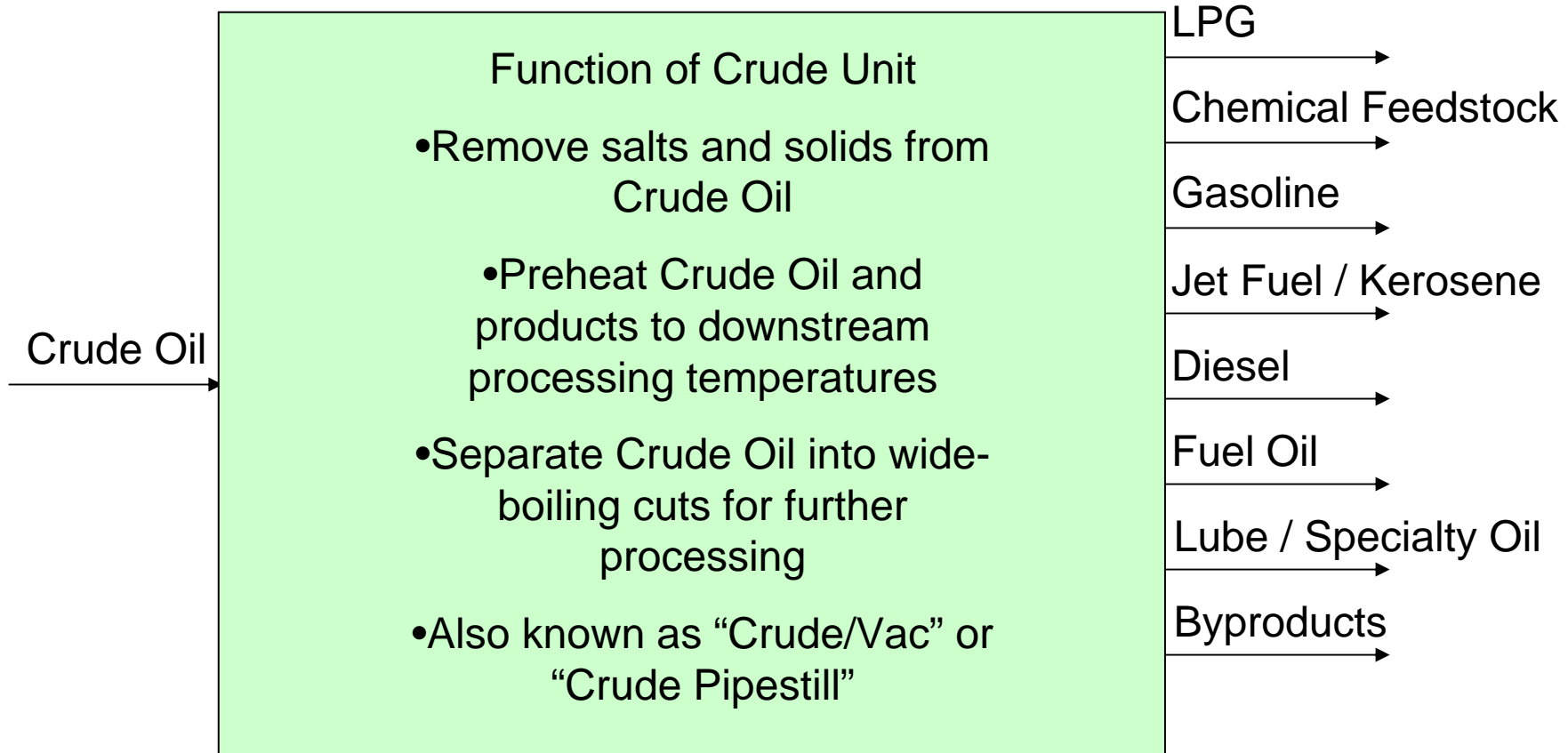

# Refinery Units and Streams

## Crude Distillation

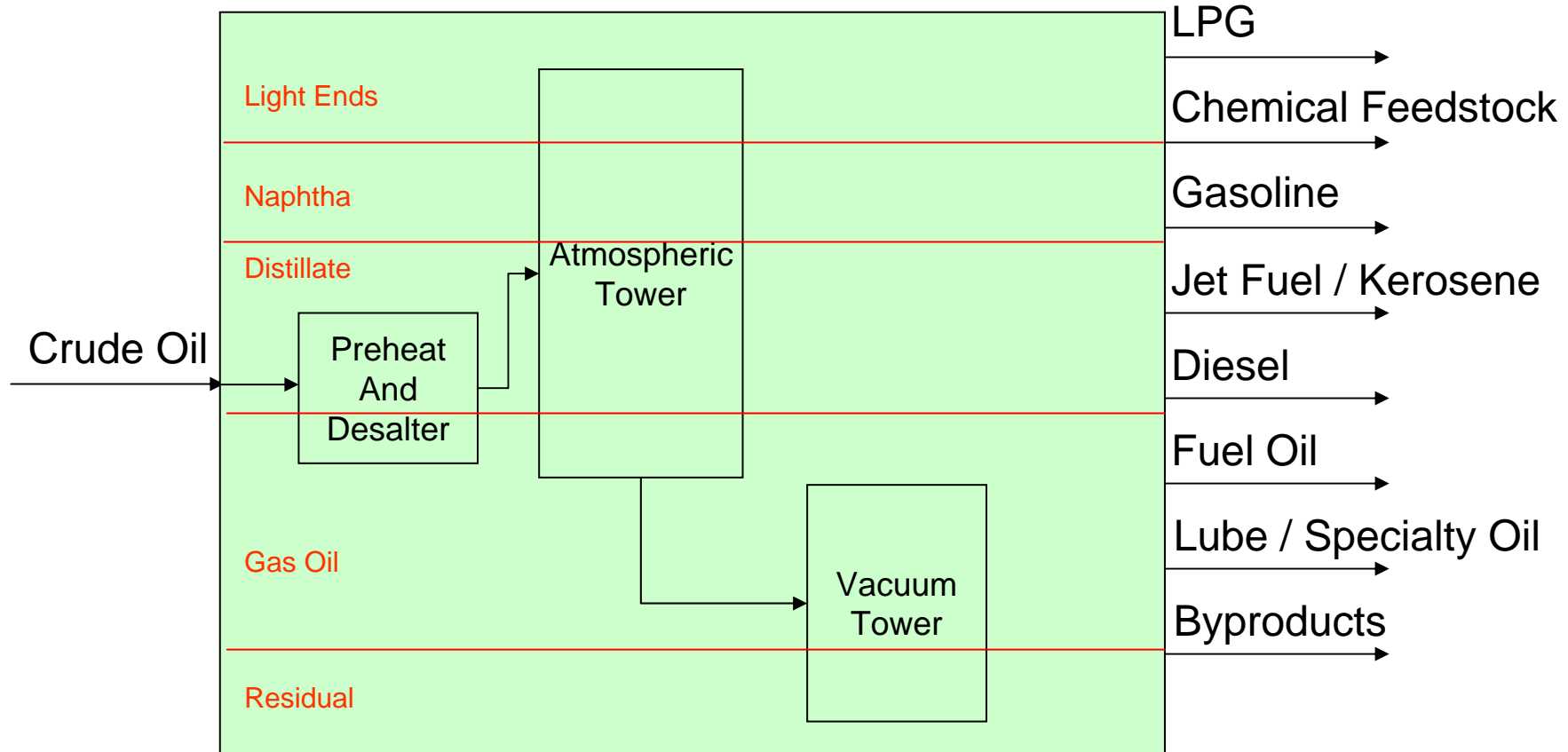

# Refinery Units and Streams

## Crude Distillation

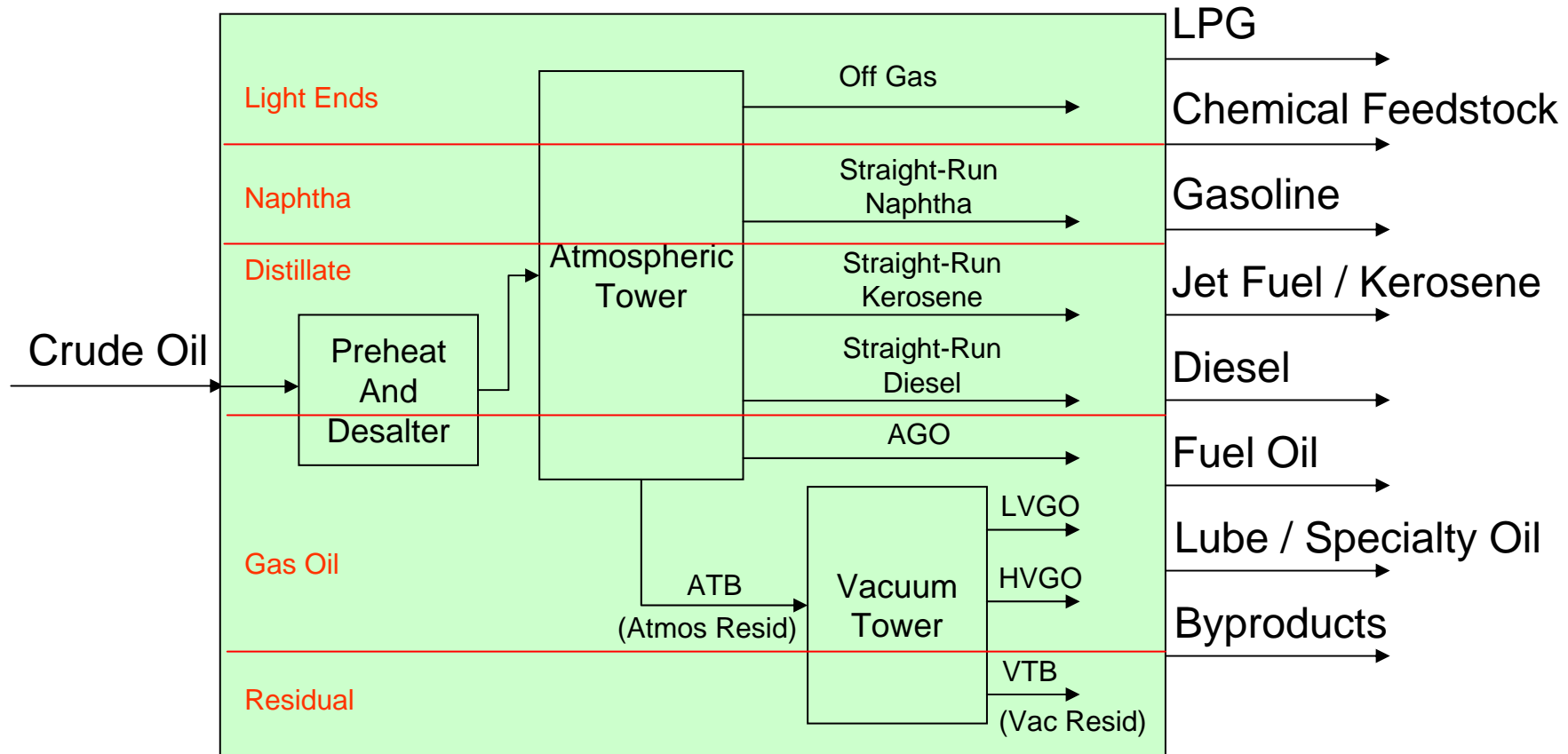

# Refinery Units and Streams

## Crude Distillation

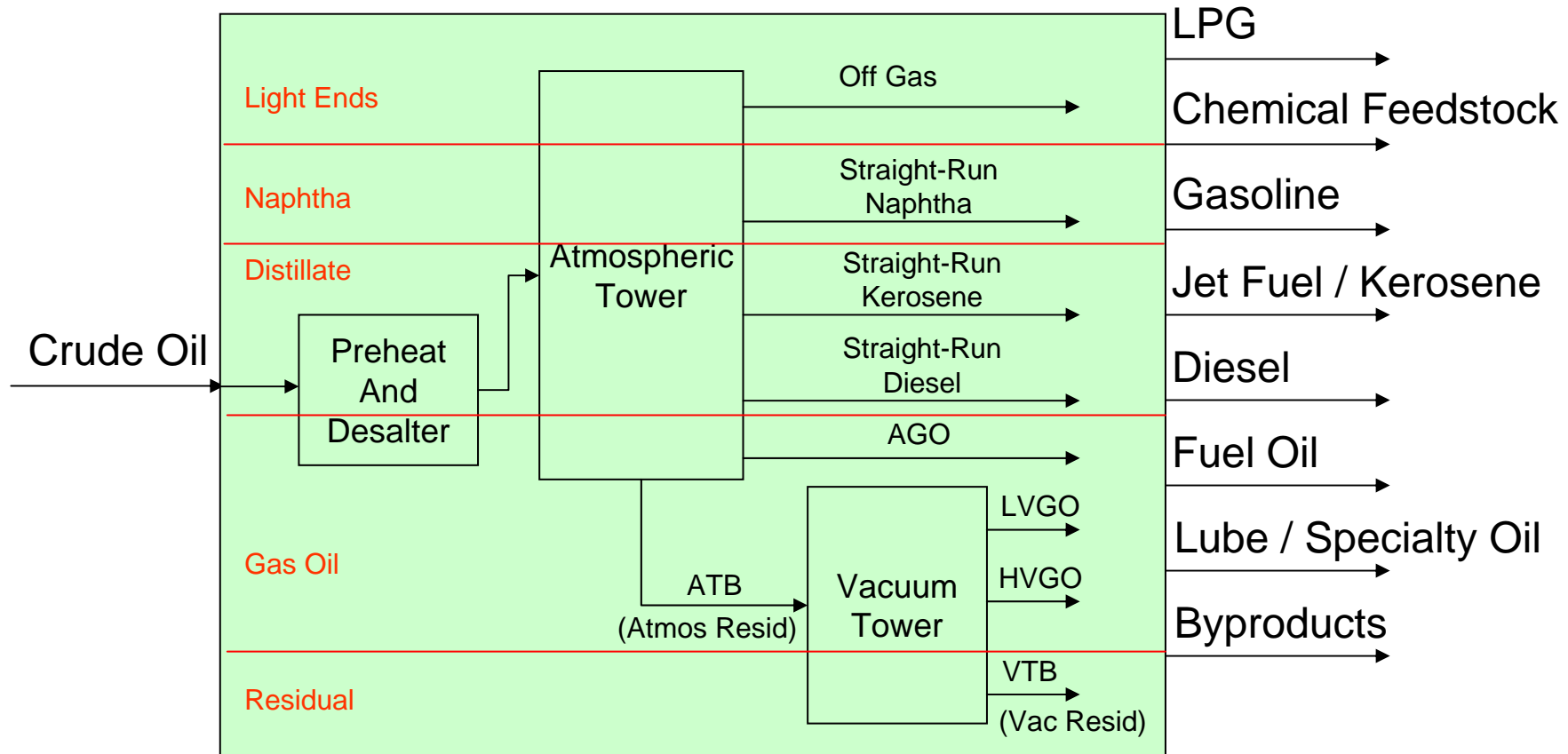

# Refinery Units and Streams

## Crude Distillation

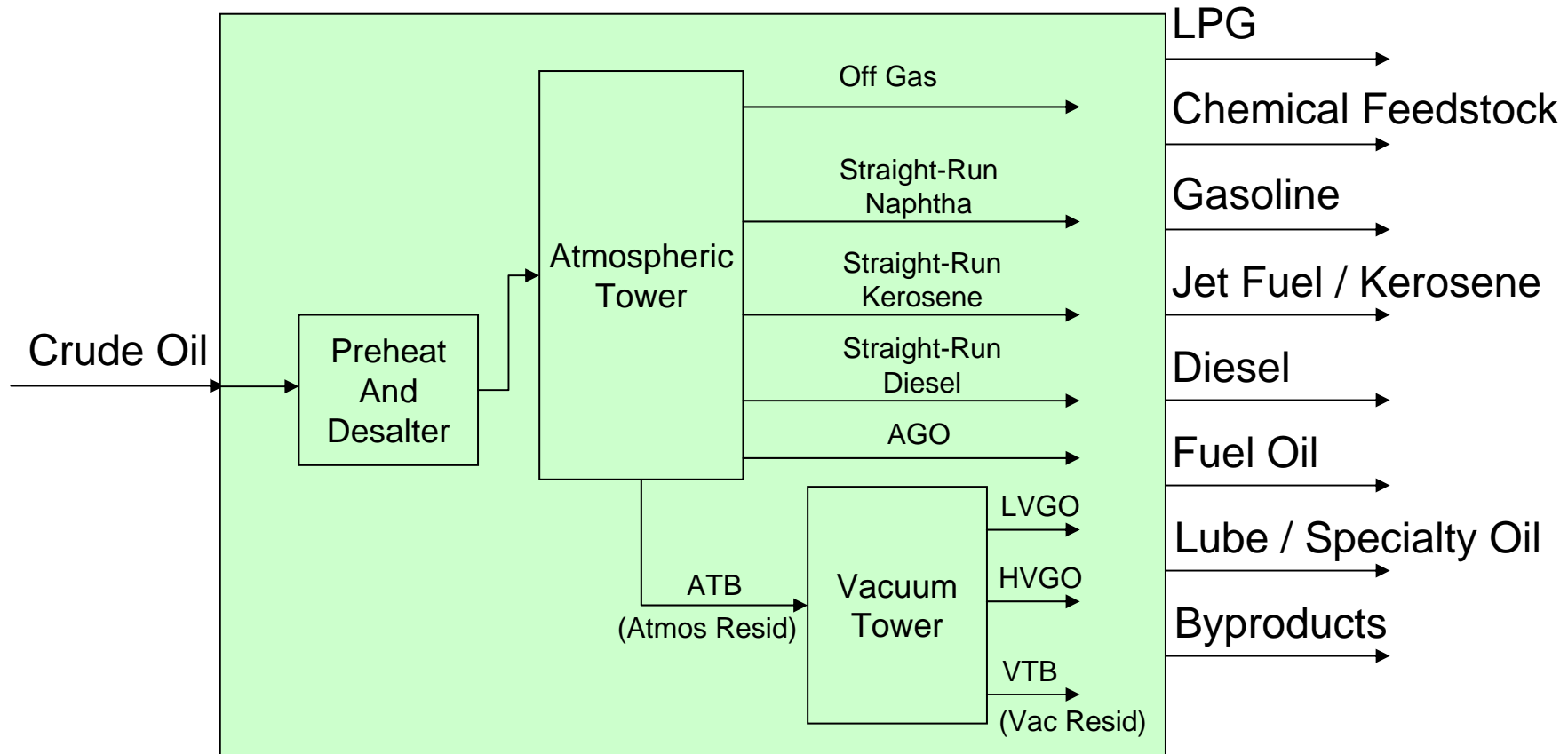

# Refinery Units and Streams

Crude  
Distillation

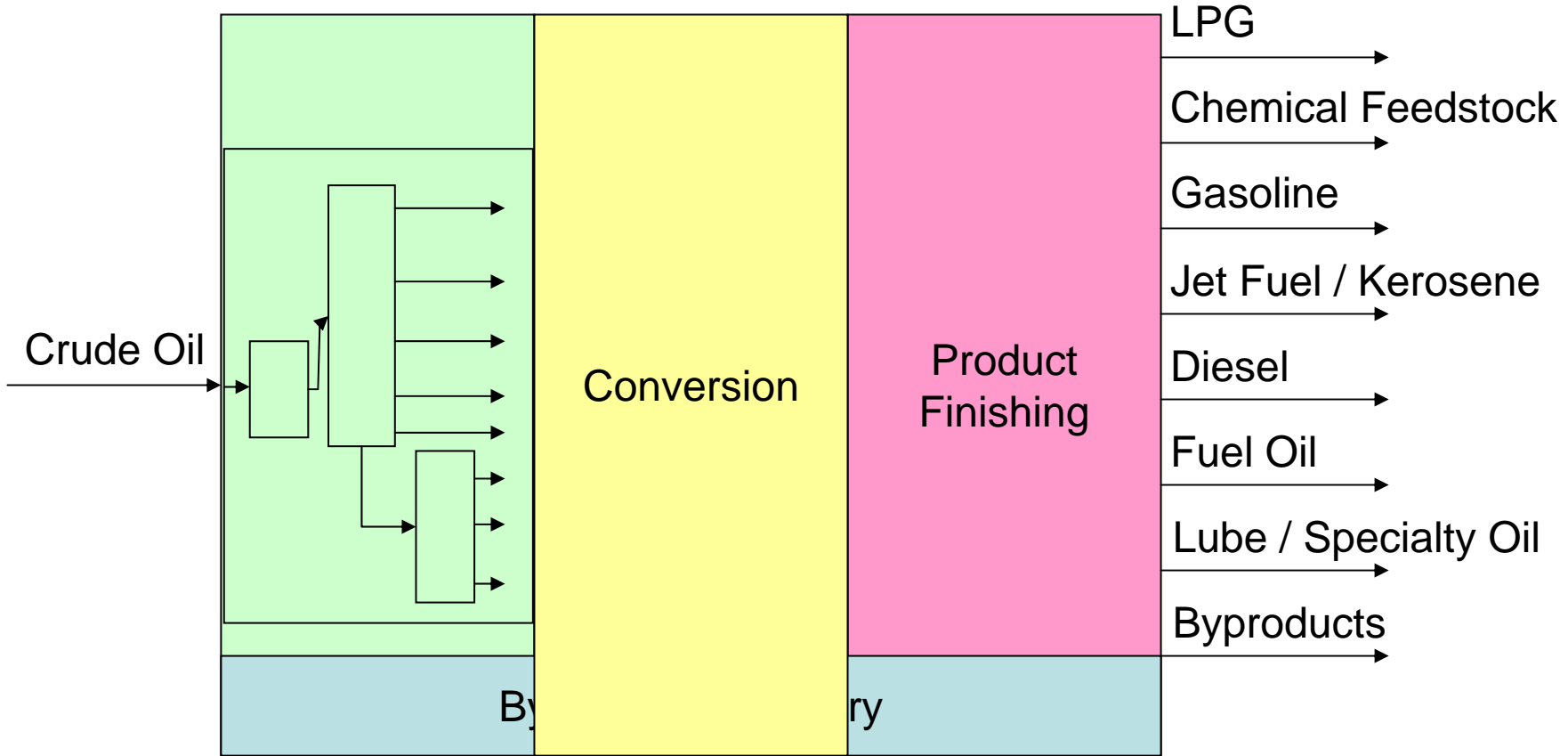

# Refinery Units and Streams

Crude  
Distillation

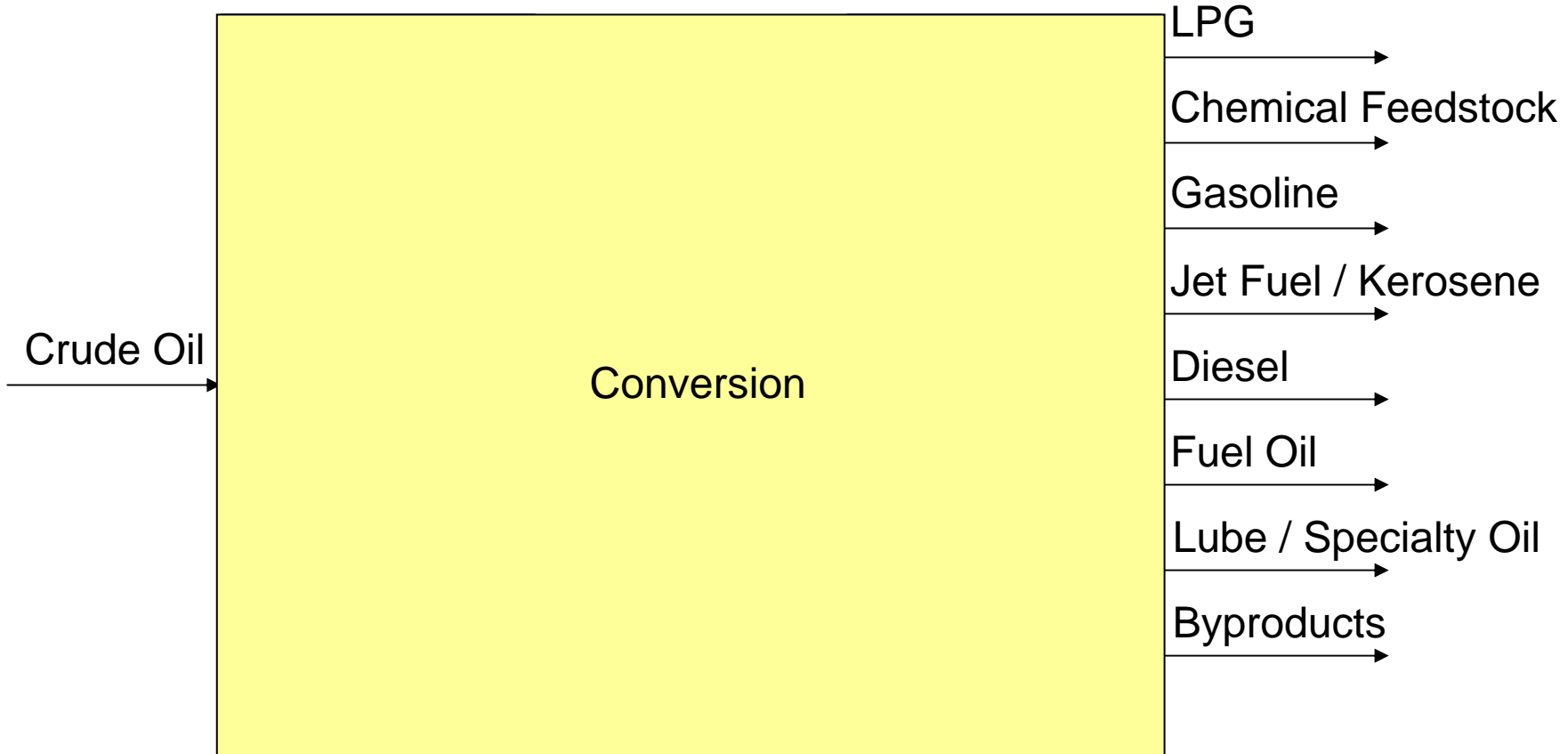

# Refinery Units and Streams

Crude  
Distillation      Conversion

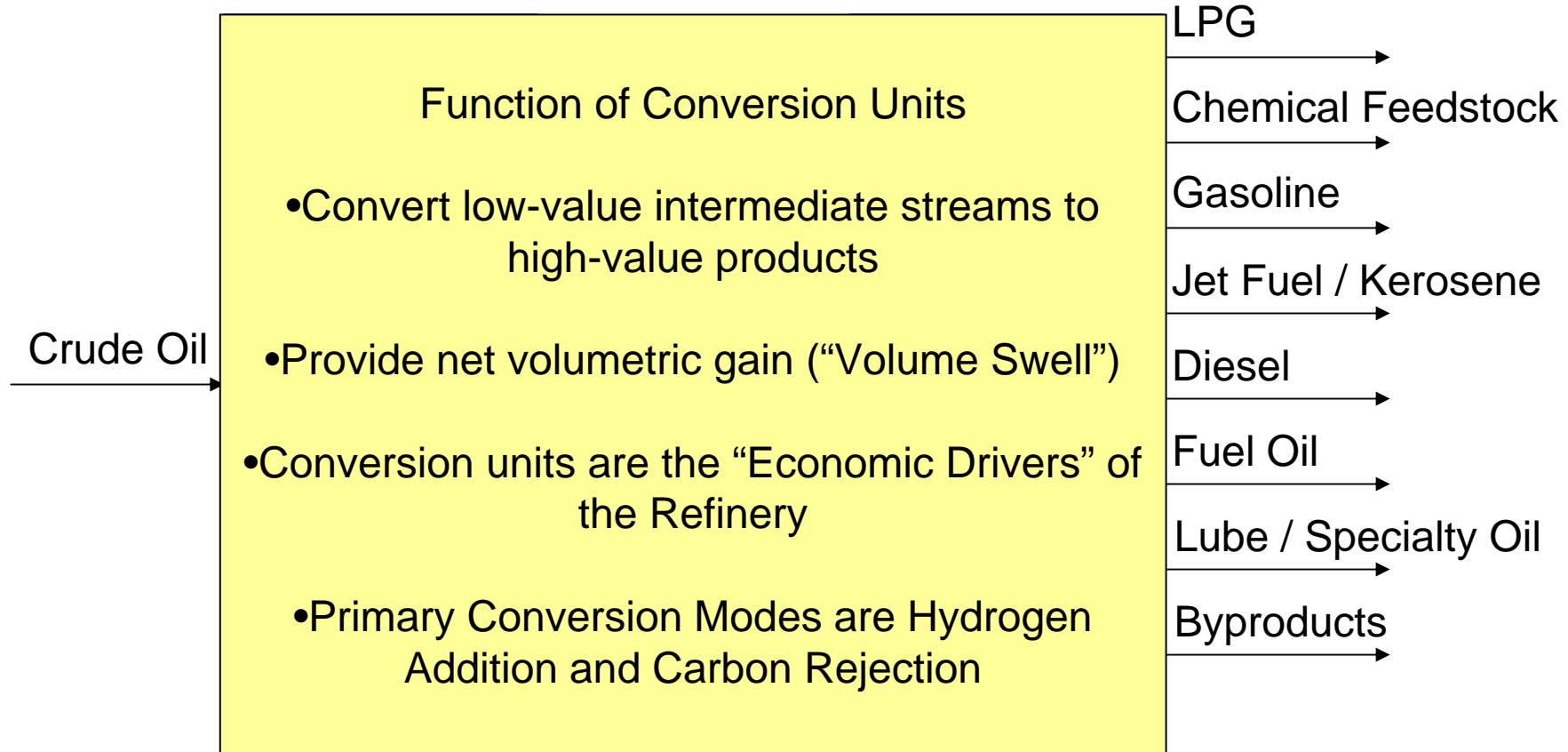

# Refinery Units and Streams

Crude  
Distillation

Conversion

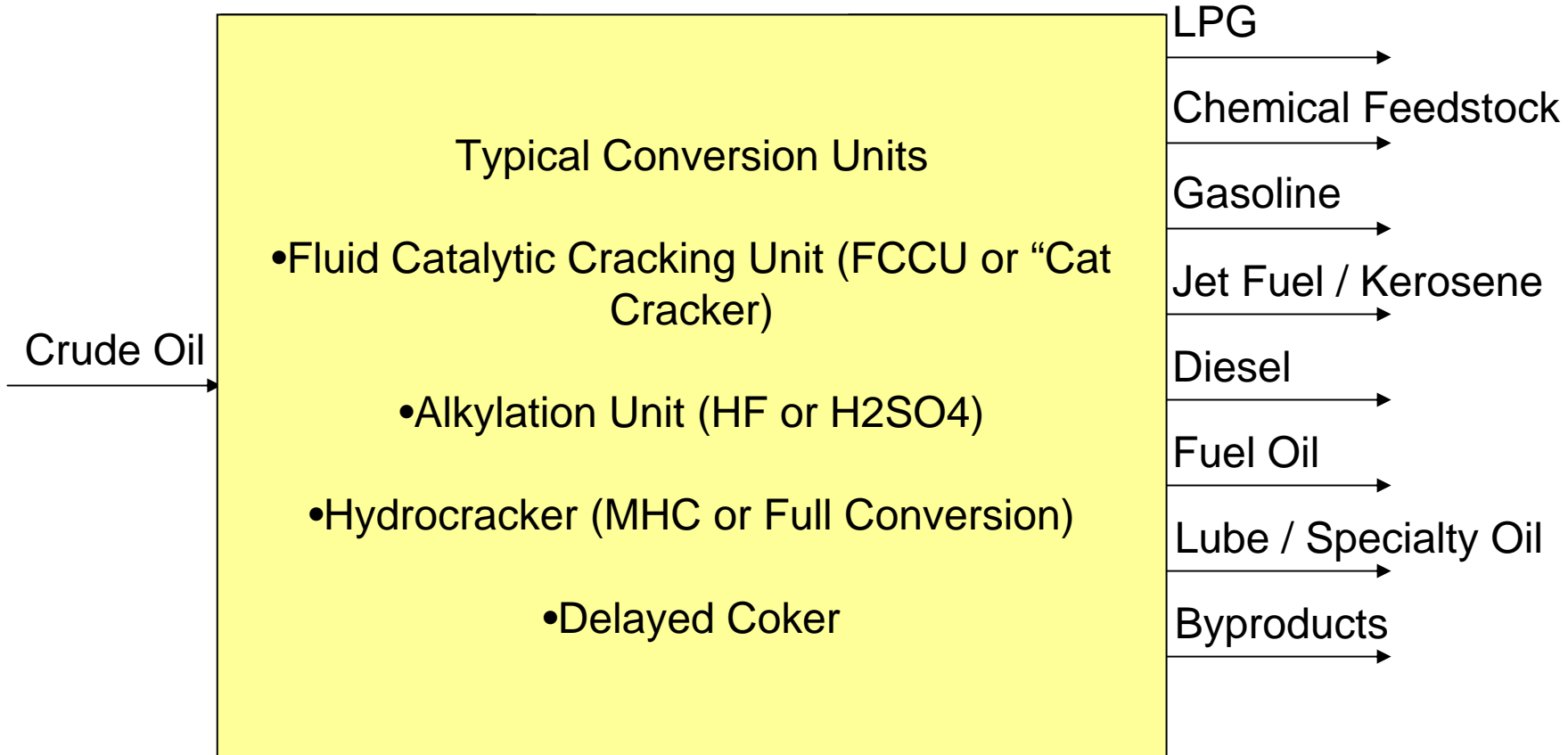

# Refinery Units and Streams

Crude  
Distillation      Conversion

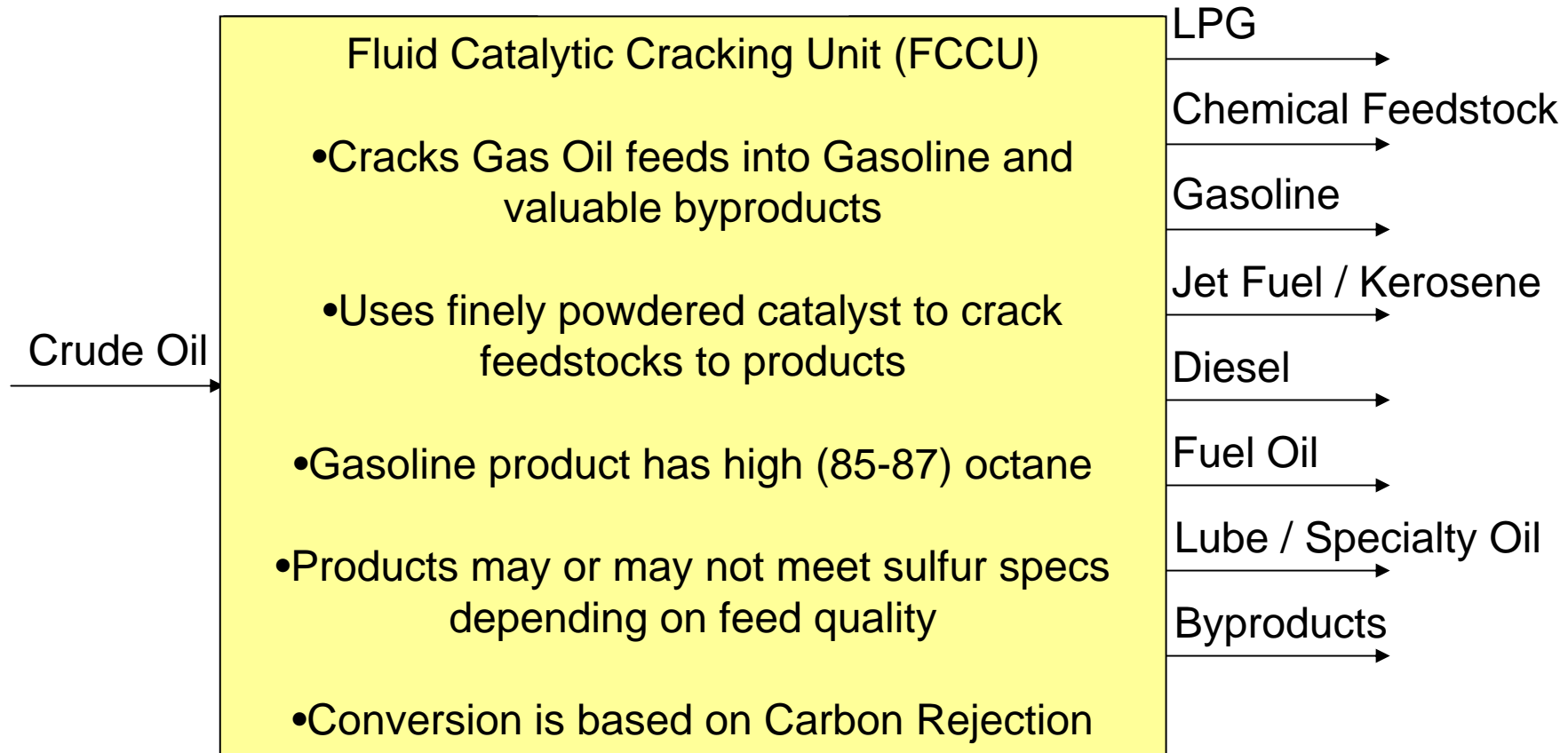



# Refinery Units and Streams

Crude Distillation      Conversion

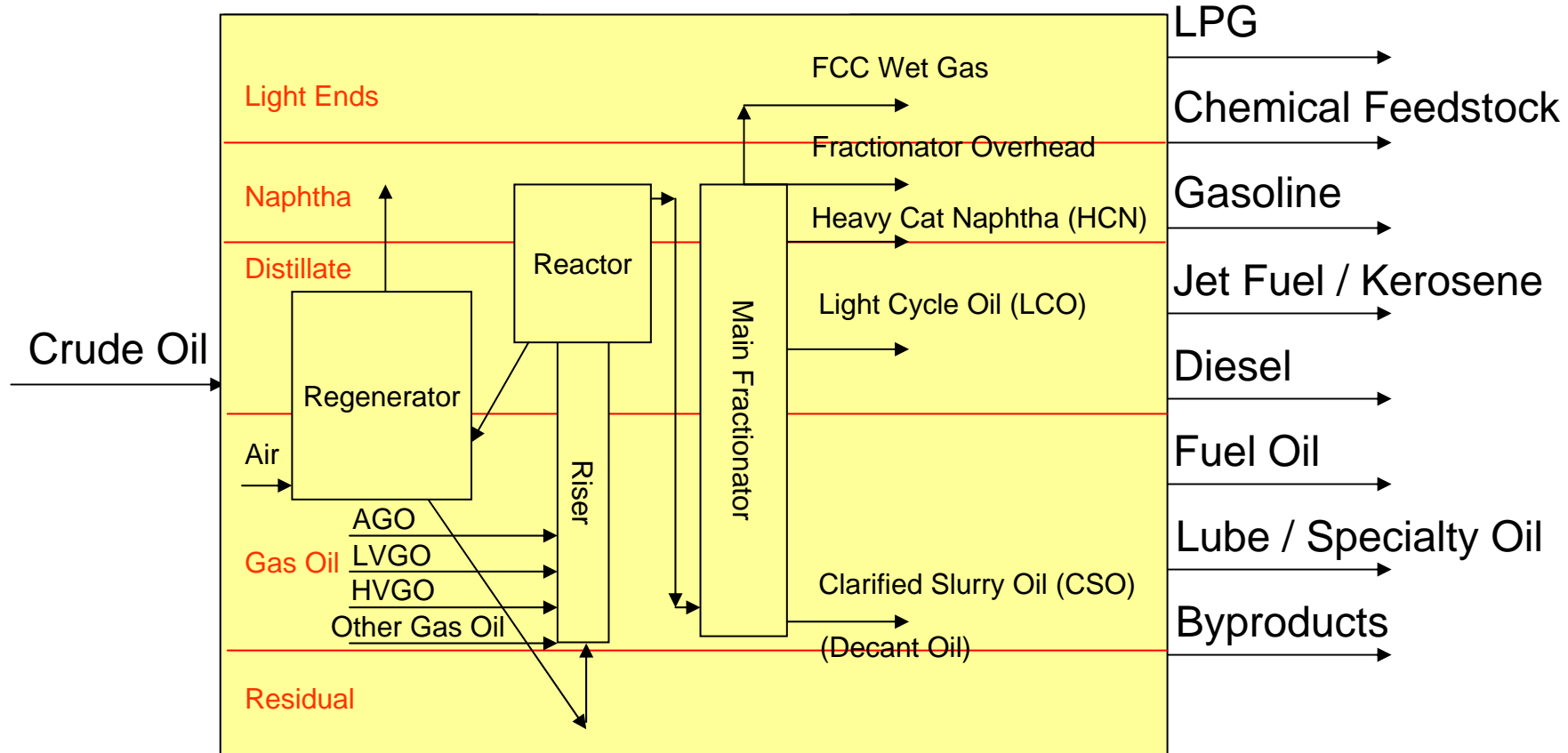

# Refinery Units and Streams

Crude  
Distillation      Conversion

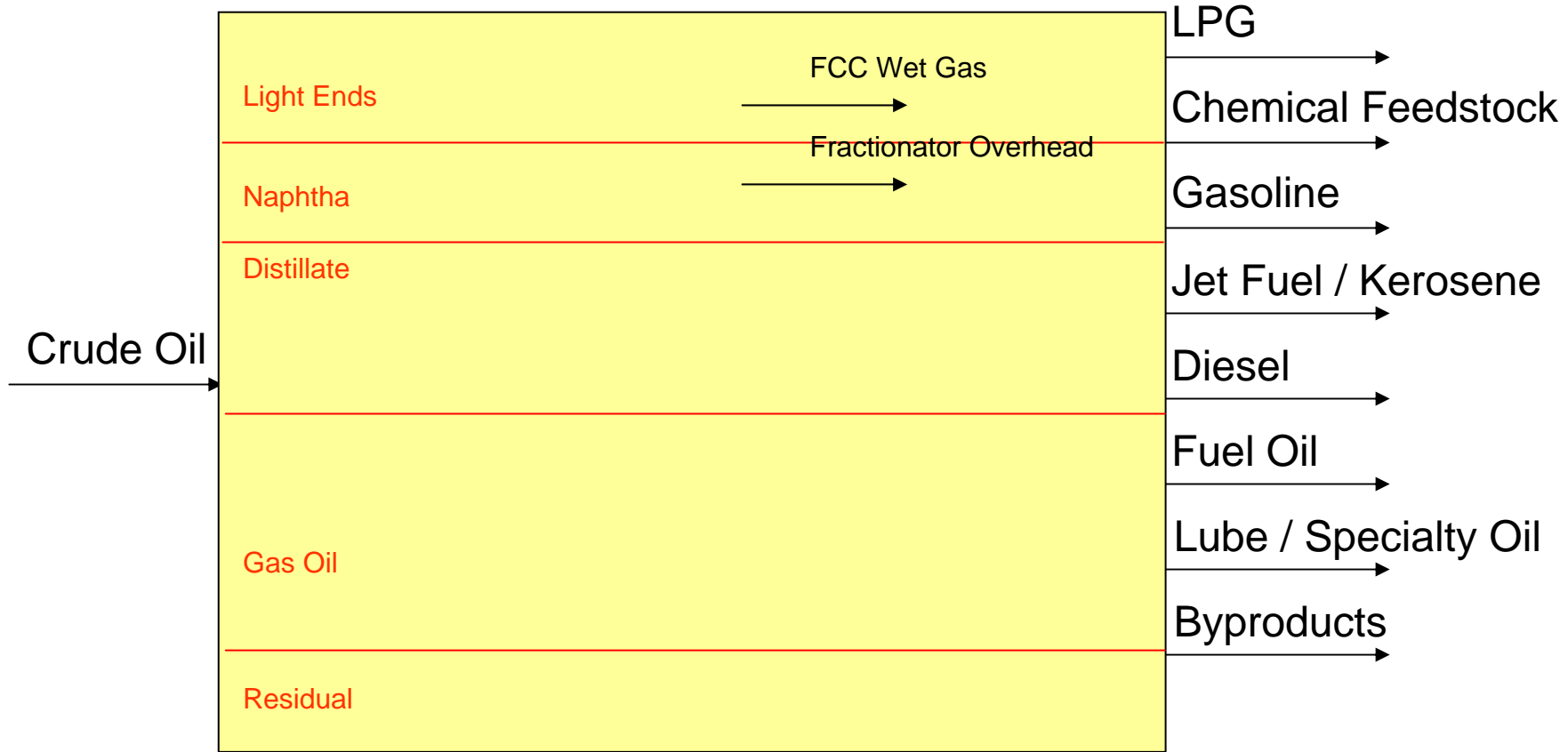

# Refinery Units and Streams

Crude  
Distillation      Conversion

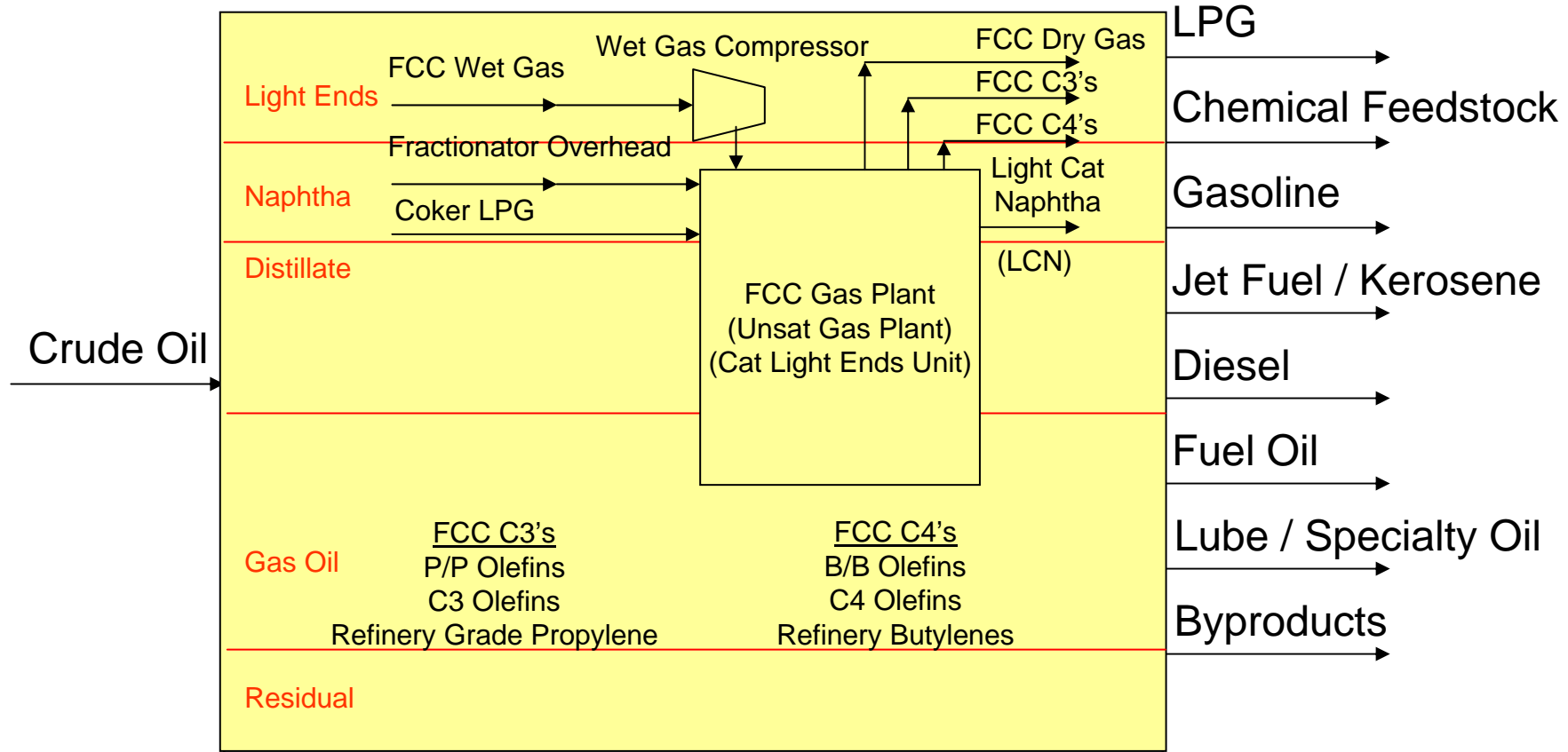

# Refinery Units and Streams

Crude  
Distillation      Conversion

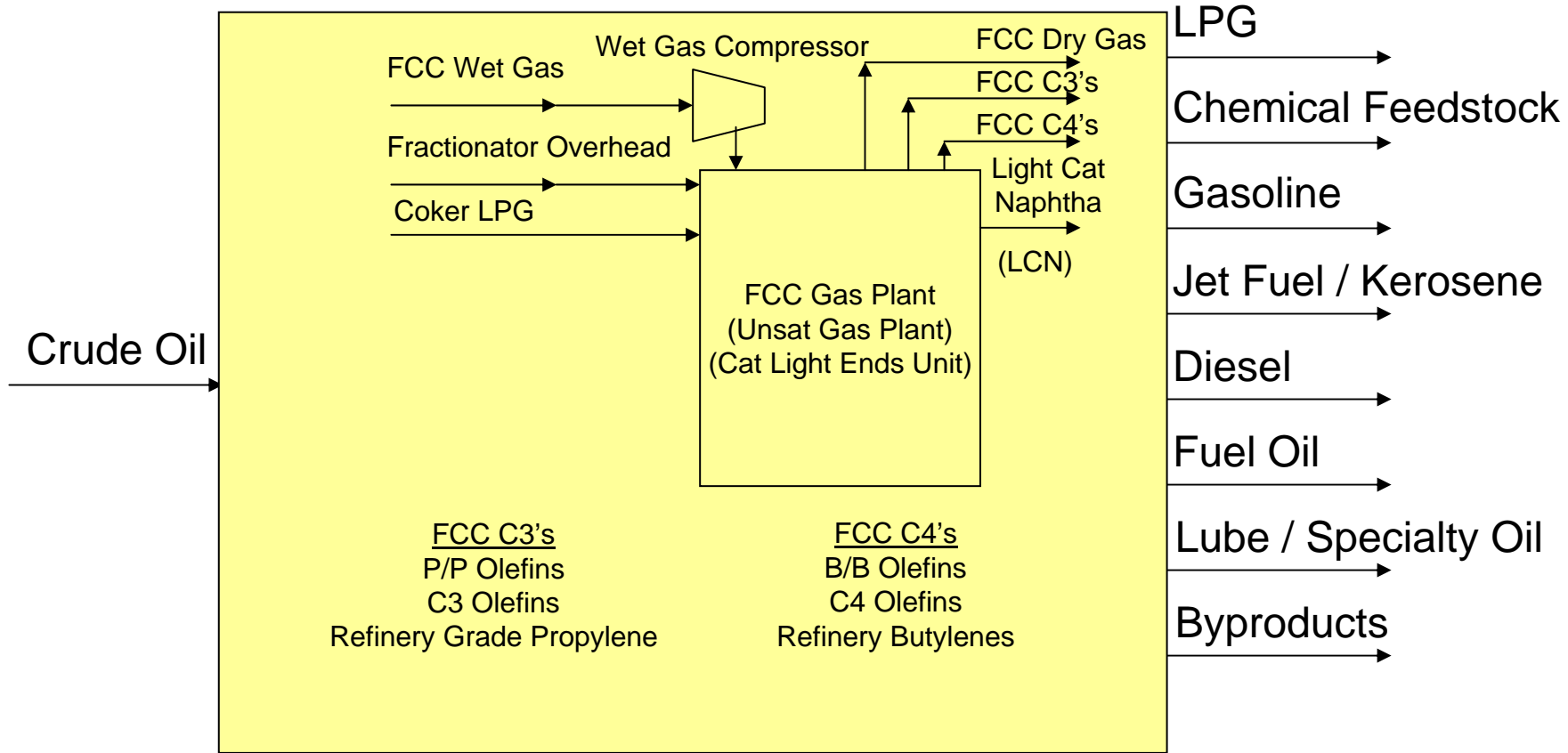

# Refinery Units and Streams

Crude  
Distillation

Conversion

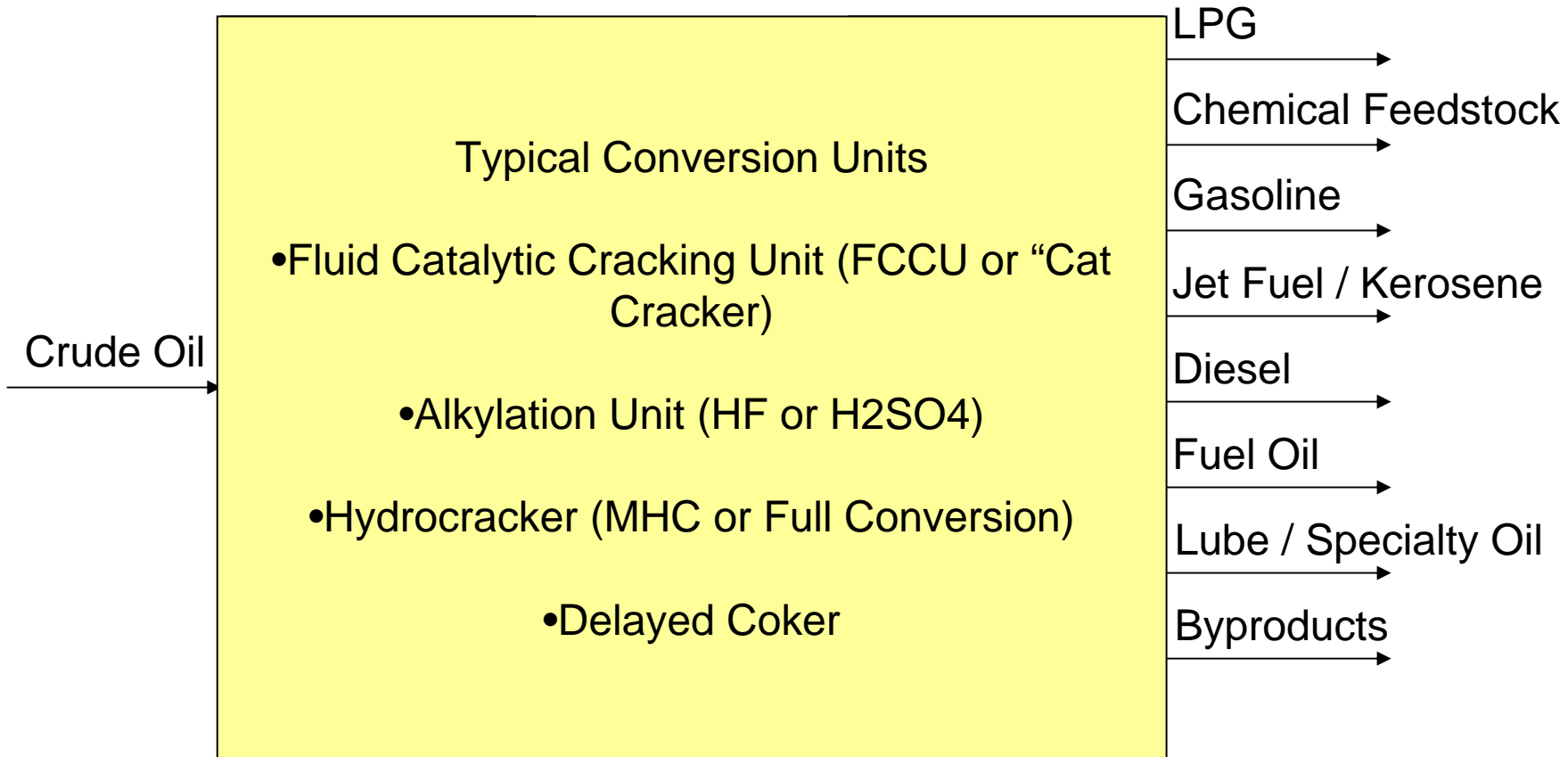

# Refinery Units and Streams

Crude  
Distillation      Conversion

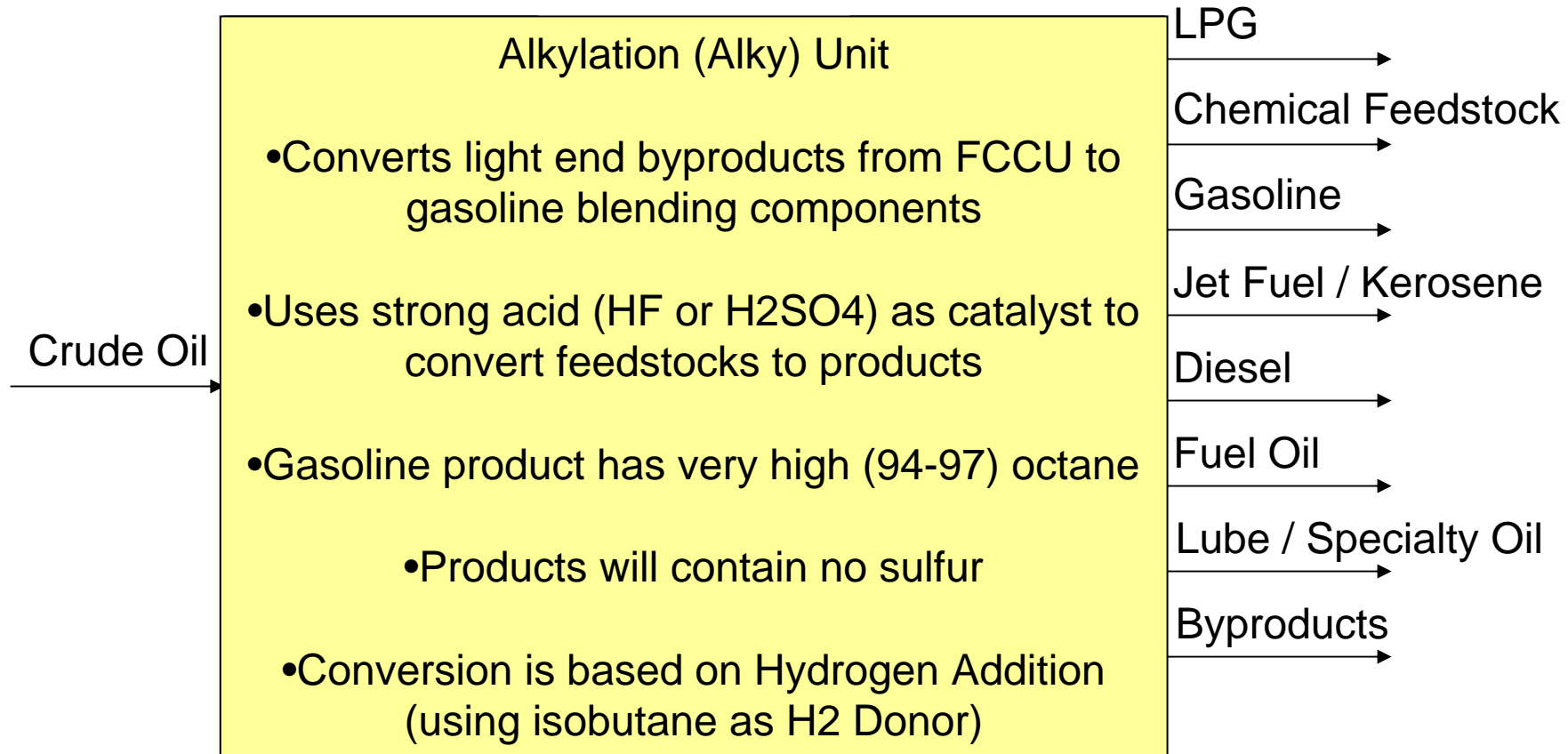

# Refinery Units and Streams

Crude  
Distillation      Conversion

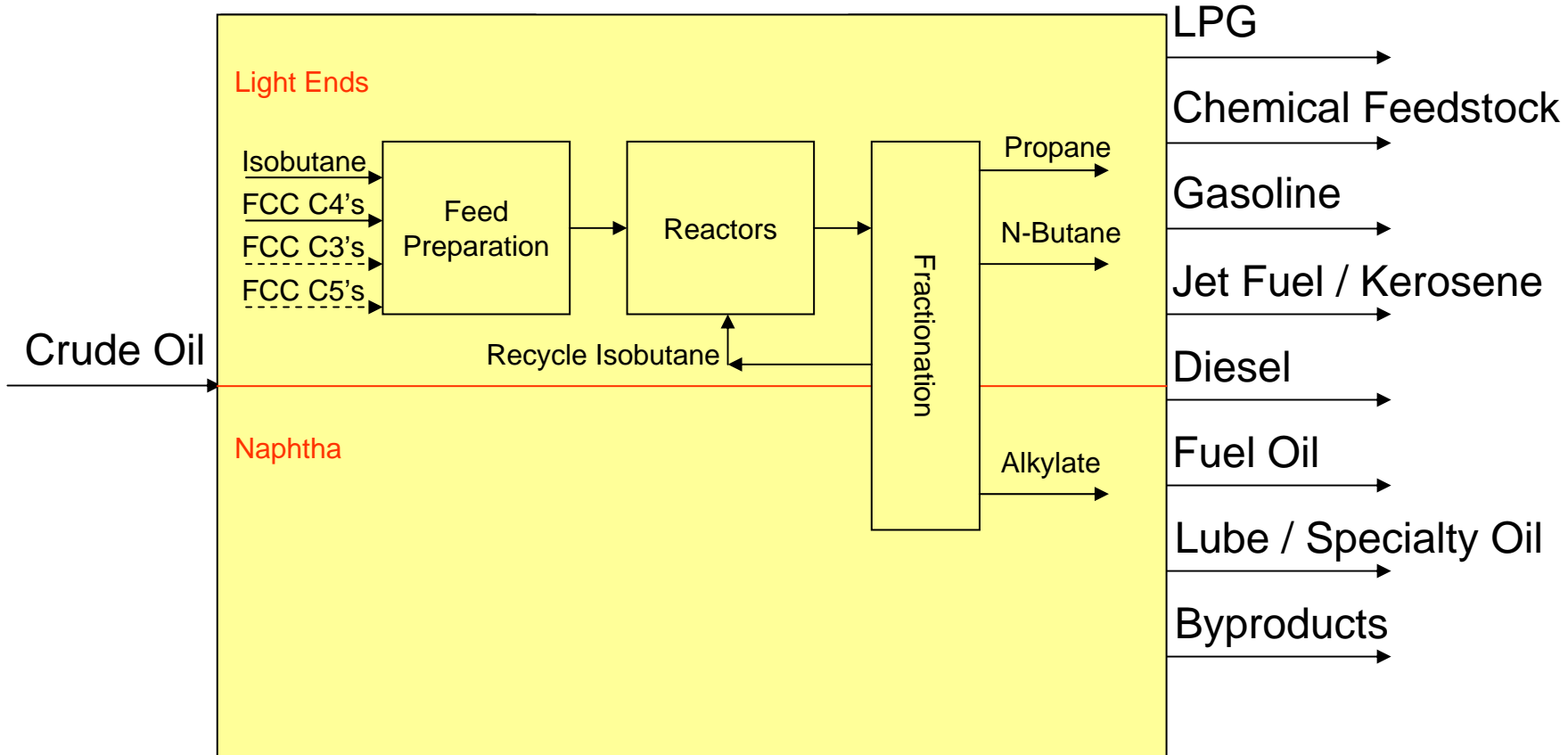

# Refinery Units and Streams

Crude  
Distillation      Conversion

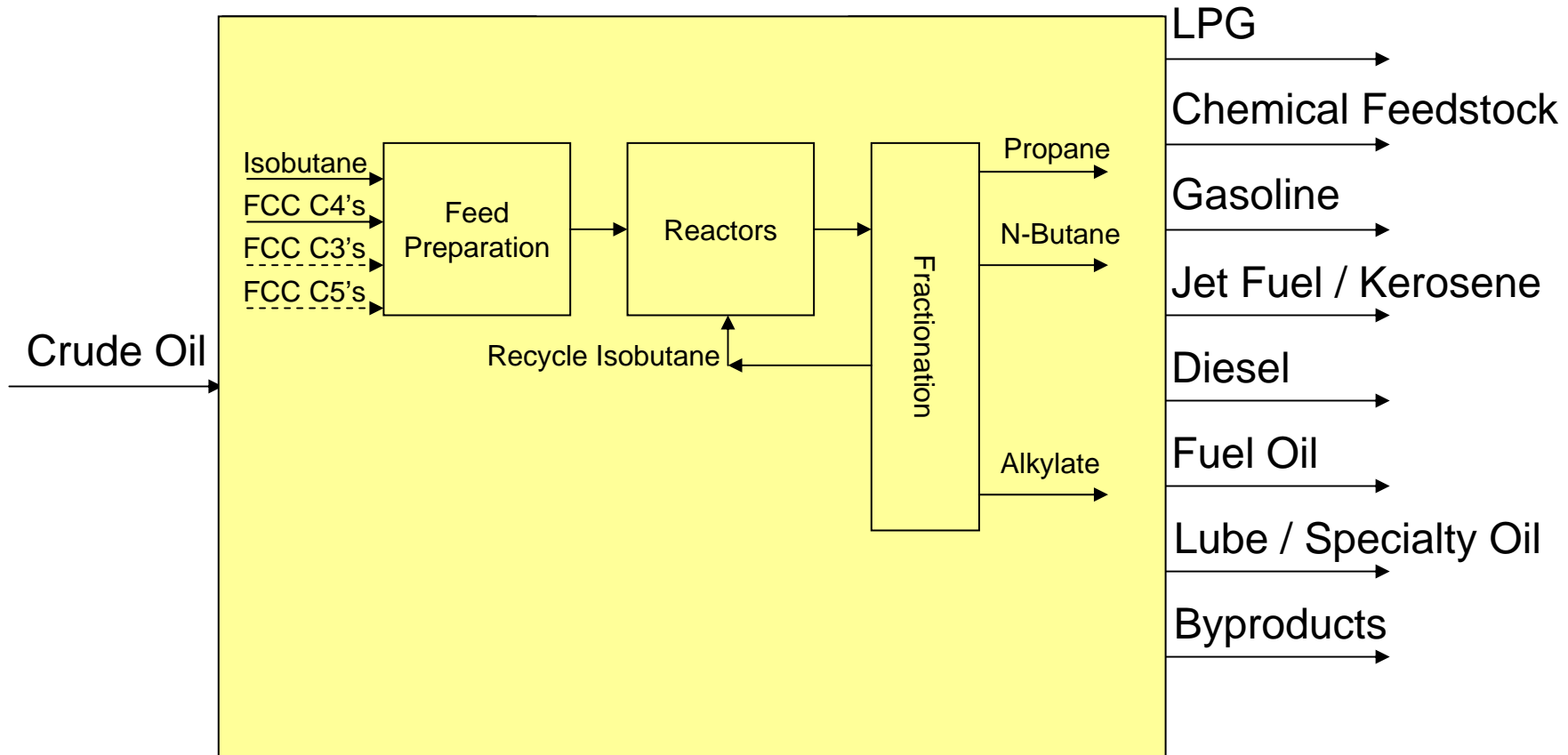

# Refinery Units and Streams

Crude  
Distillation

Conversion

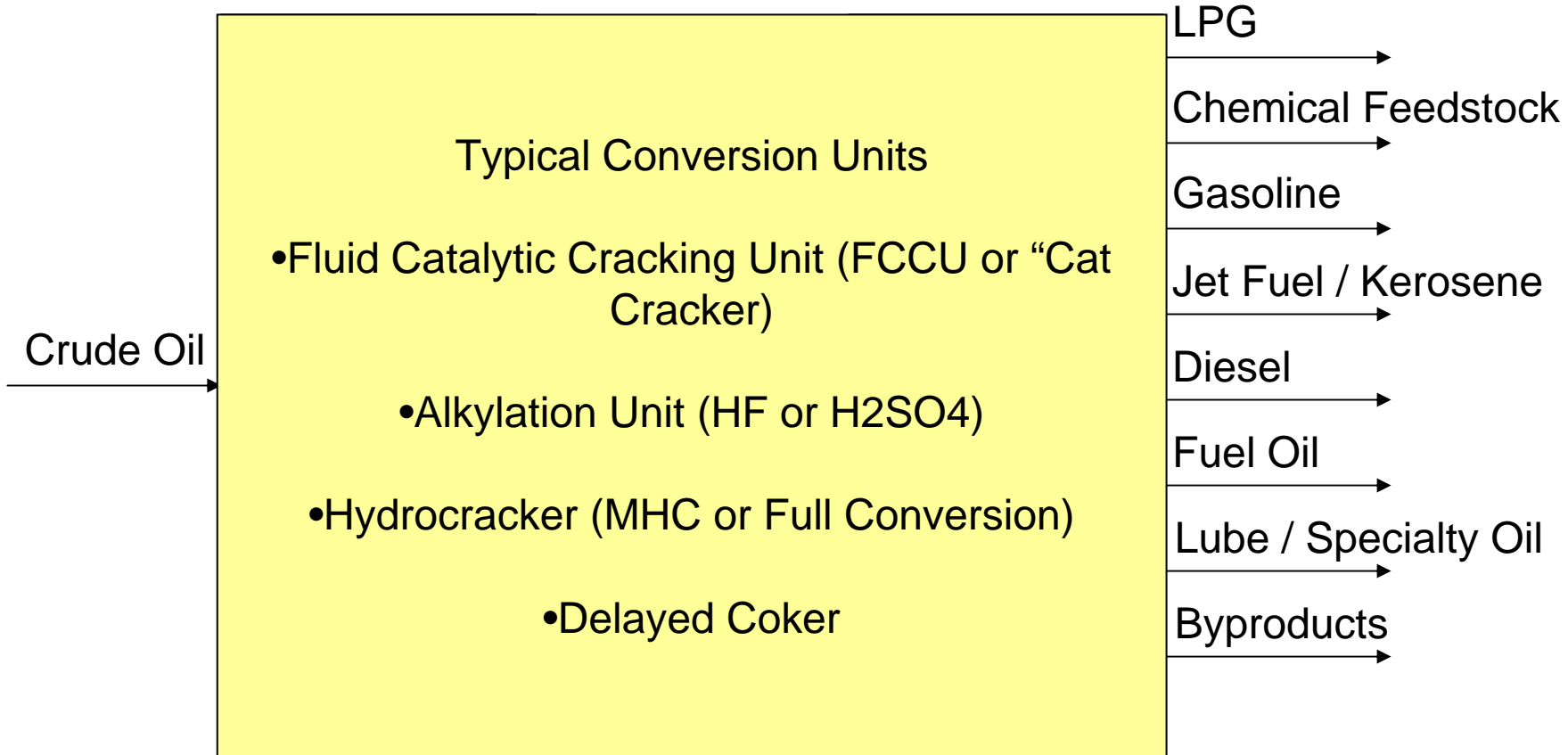

# Refinery Units and Streams

Crude  
Distillation

Conversion

## Hydrocracker Unit

- Converts Gas Oil and other low-value Refinery streams to diesel and gasoline
- Uses hydrogen and solid catalyst to convert feedstocks to products
- Gasoline product has medium (80-85) octane - makes good CCR feedstock
- Diesel product has excellent cetane properties
  - Products will meet low-sulfur specs
- Conversion is based on Hydrogen Addition

LPG

Chemical Feedstock

Gasoline

Jet Fuel / Kerosene

Diesel

Fuel Oil

Lube / Specialty Oil

Byproducts

Crude Oil

# Refinery Units and Streams

Crude Distillation      Conversion

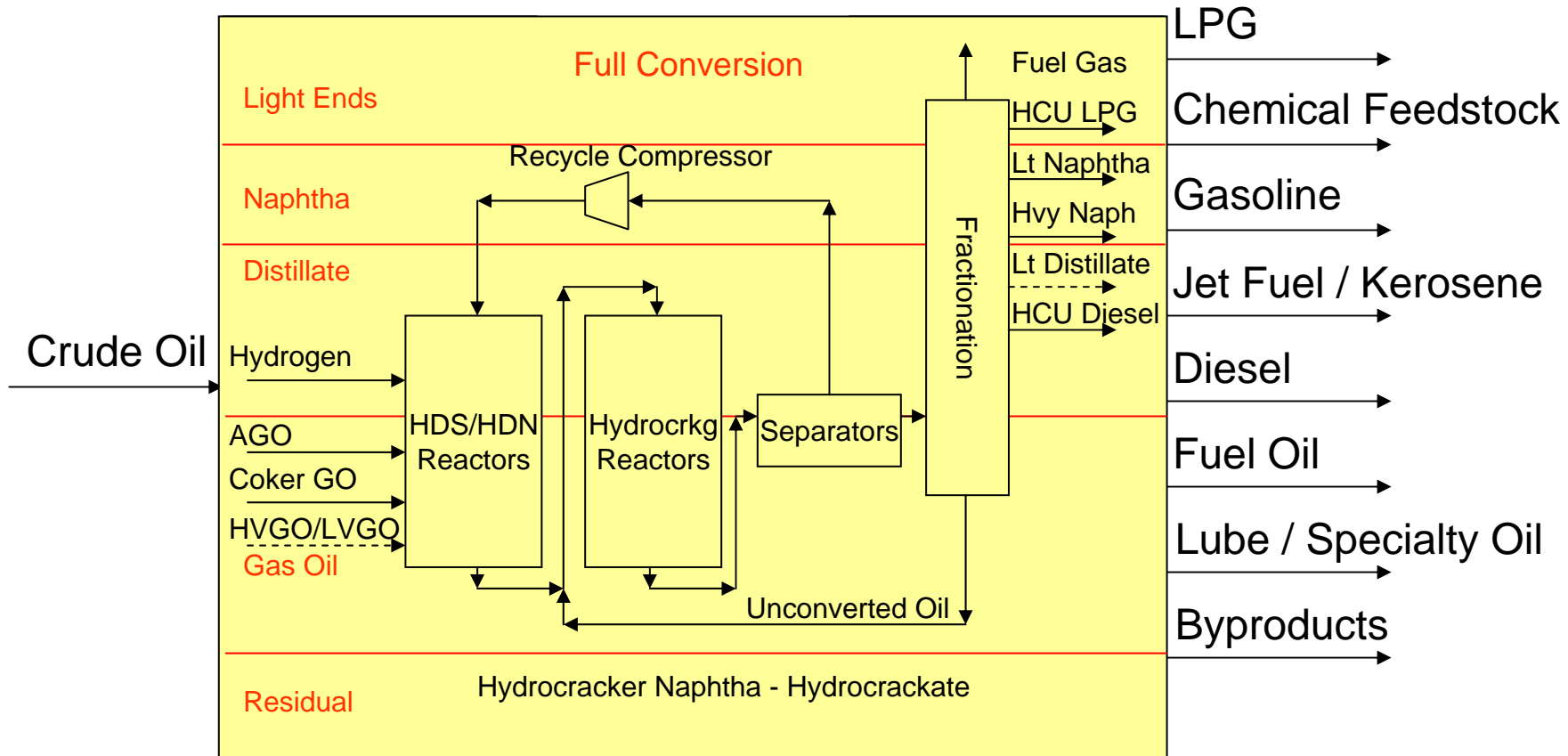

# Refinery Units and Streams

Crude Distillation      Conversion

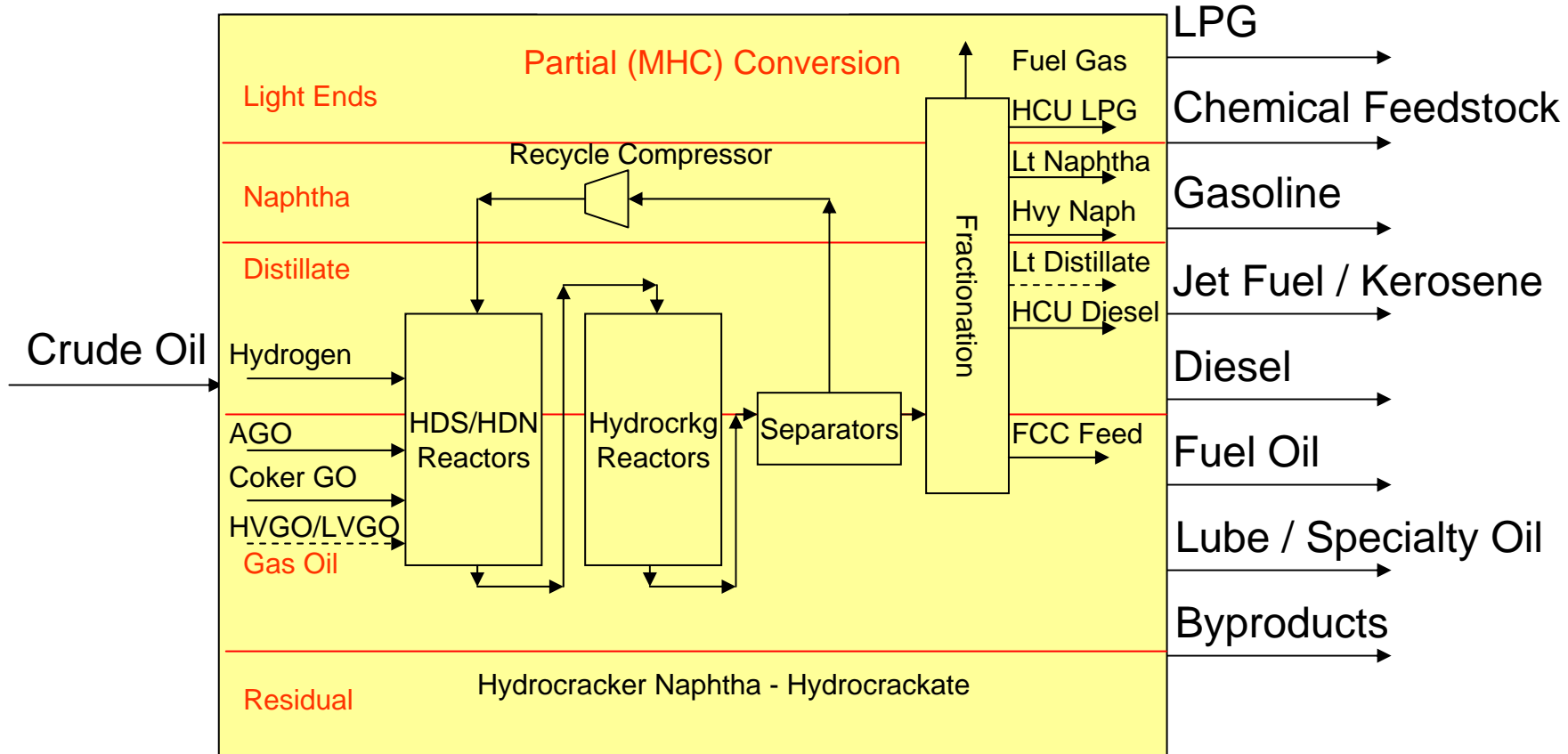

# Refinery Units and Streams

Crude Distillation      Conversion

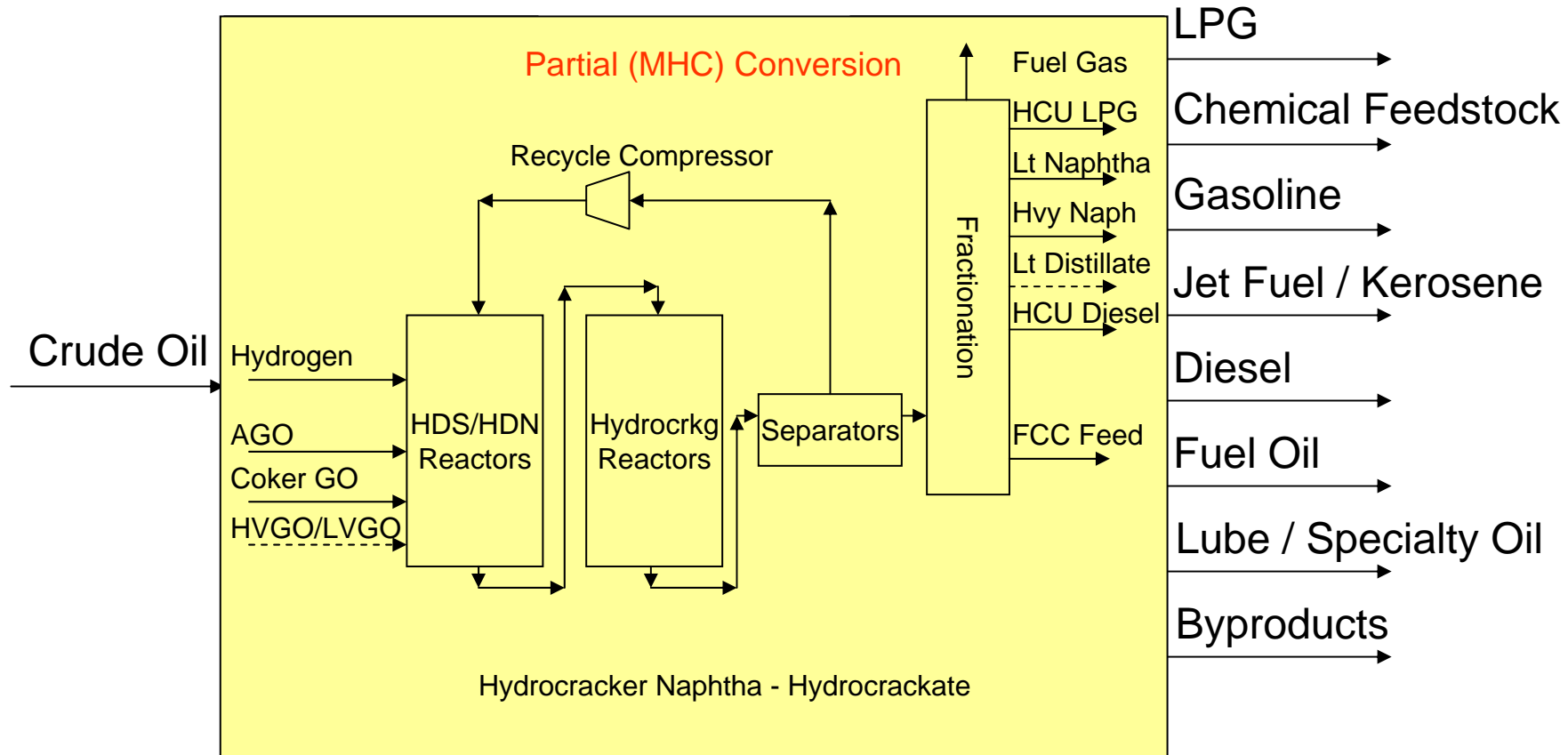

# Refinery Units and Streams

Crude  
Distillation

Conversion

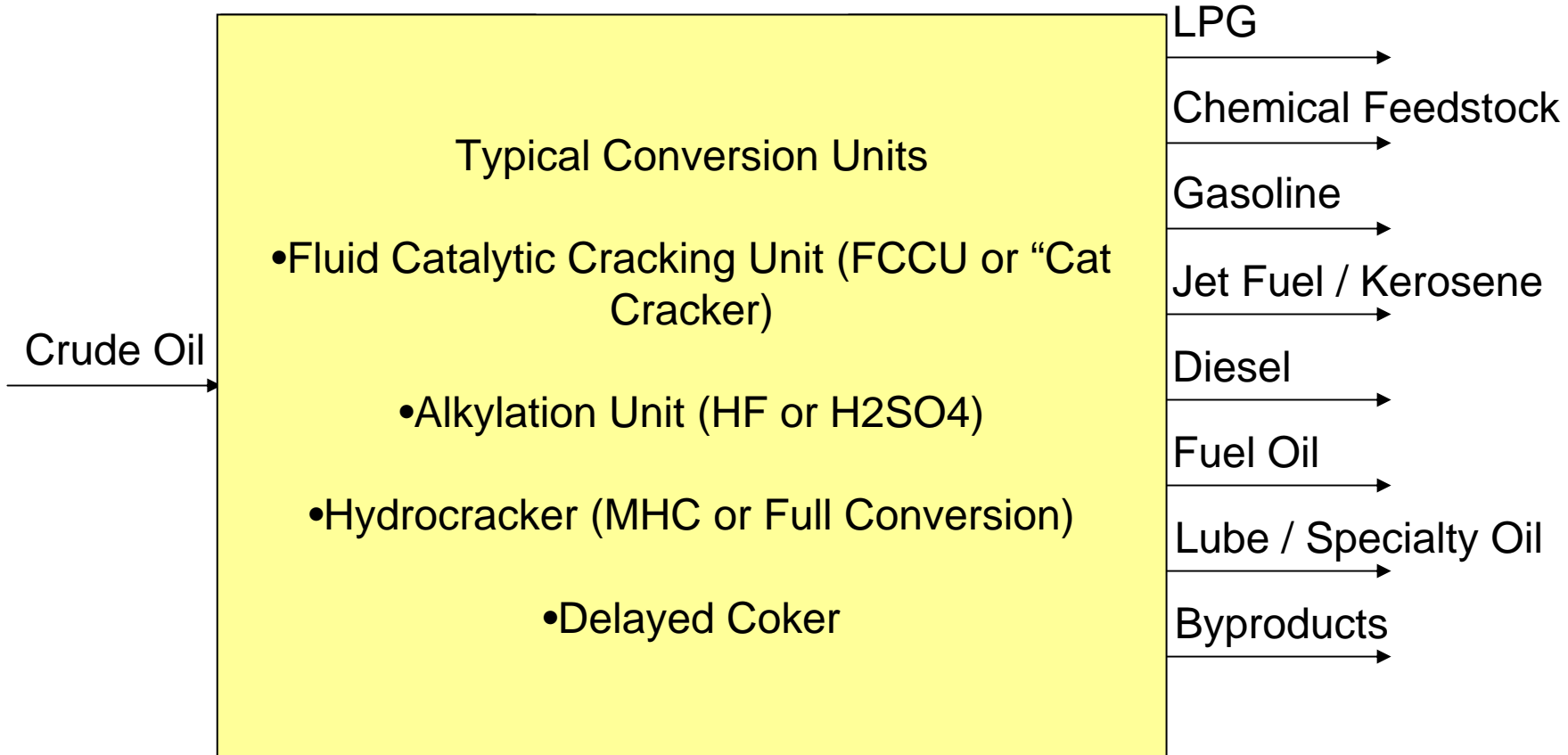

# Refinery Units and Streams

Crude  
Distillation      Conversion

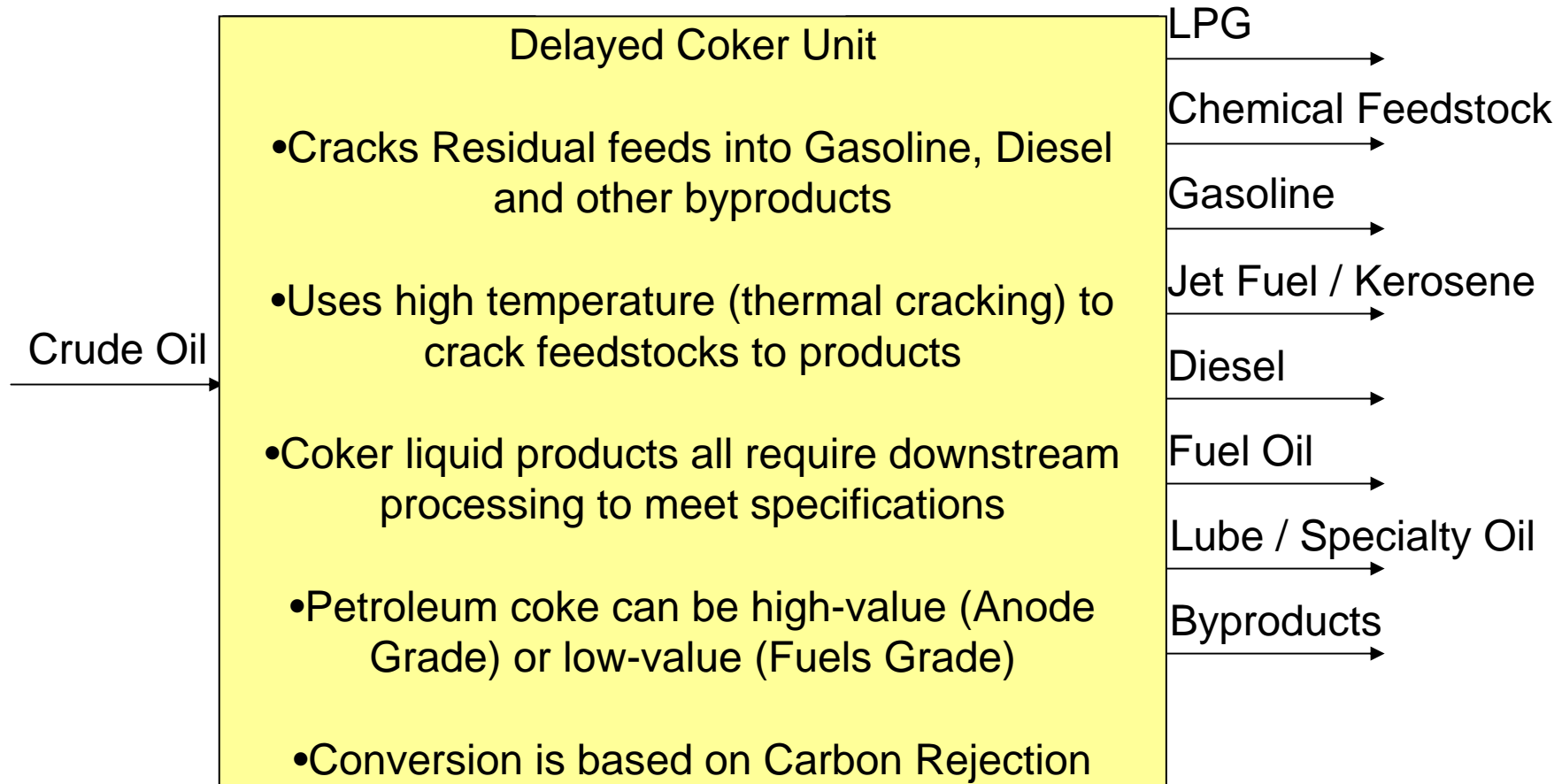

# Refinery Units and Streams

Crude  
Distillation      Conversion

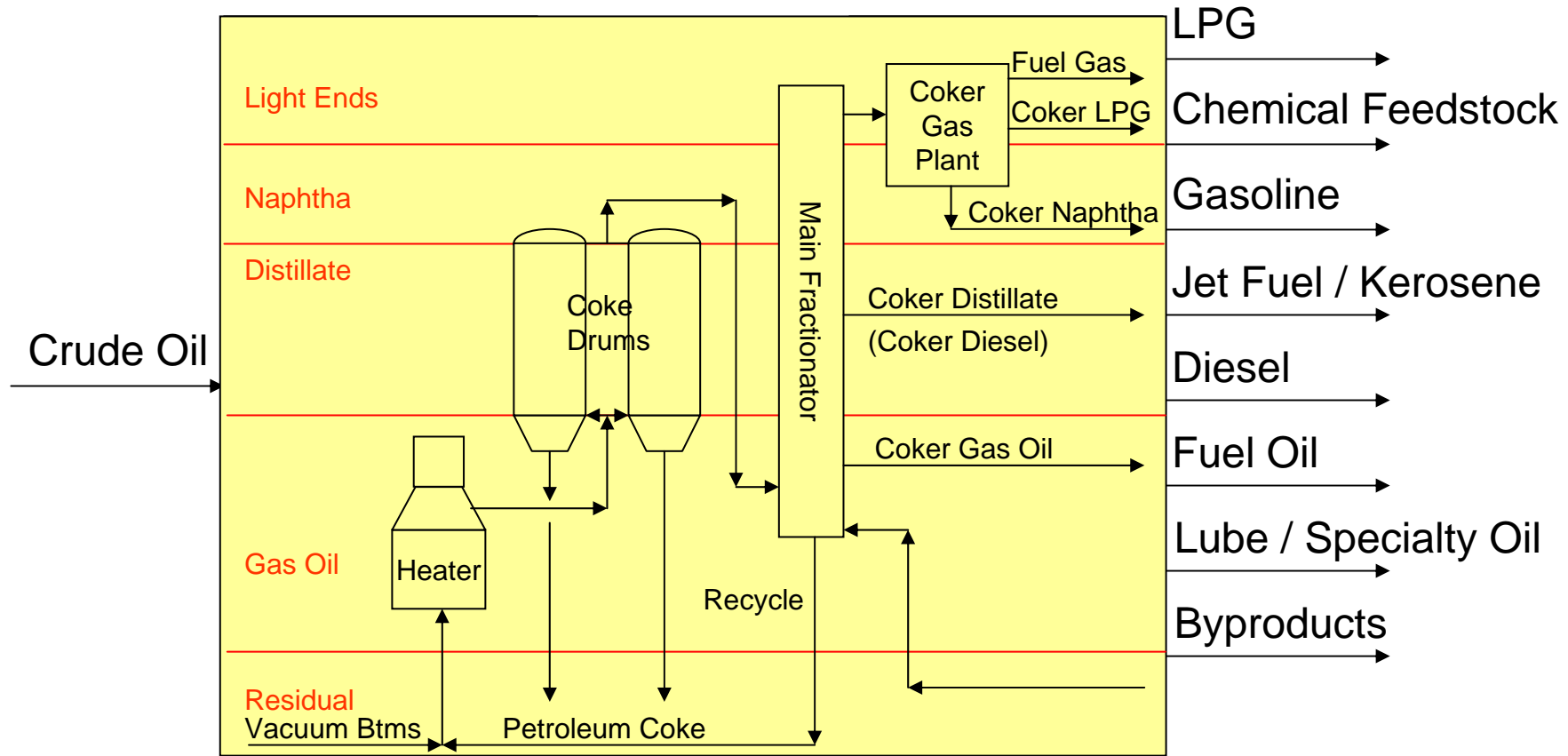

# Refinery Units and Streams

Crude  
Distillation      Conversion

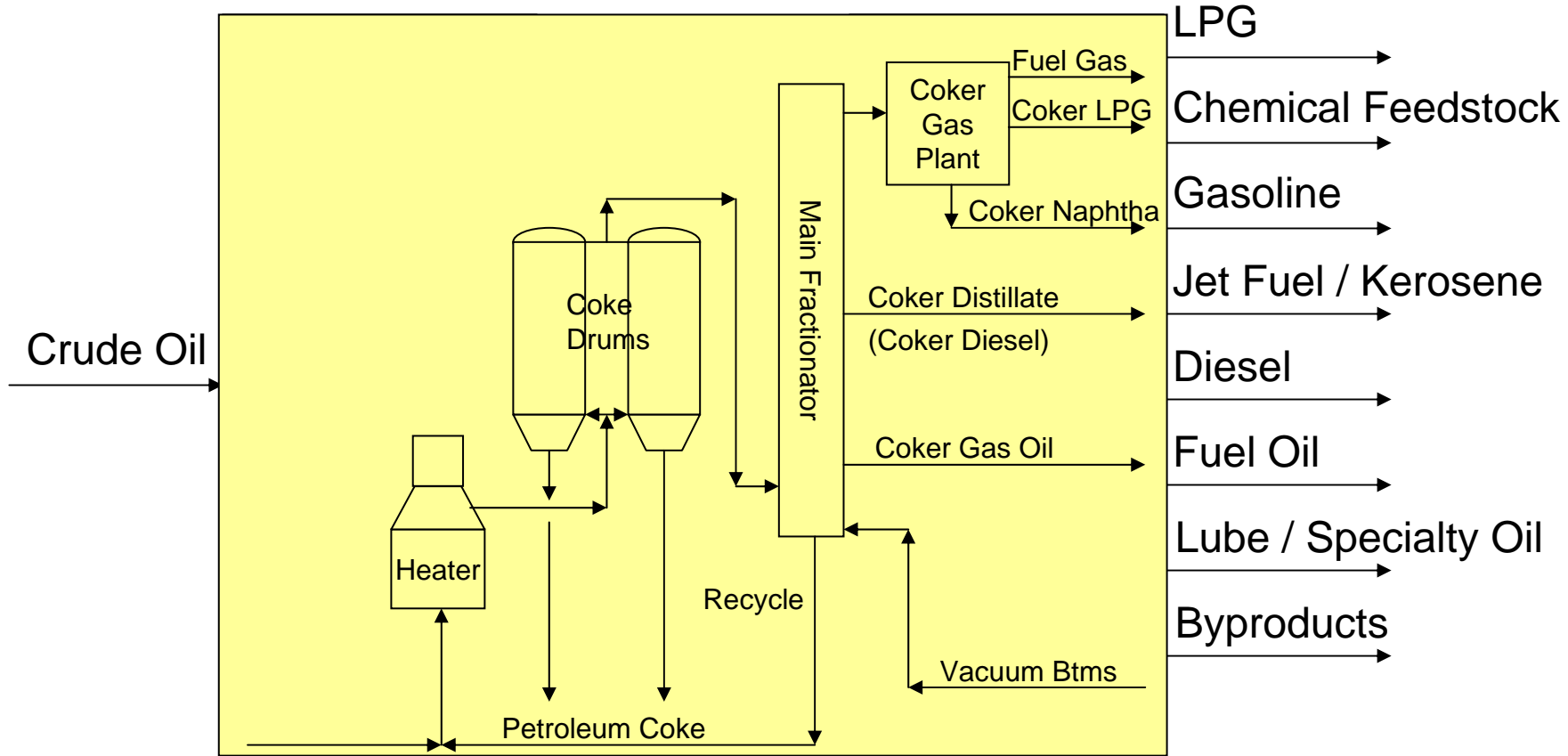

# Refinery Units and Streams

Crude  
Distillation      Conversion

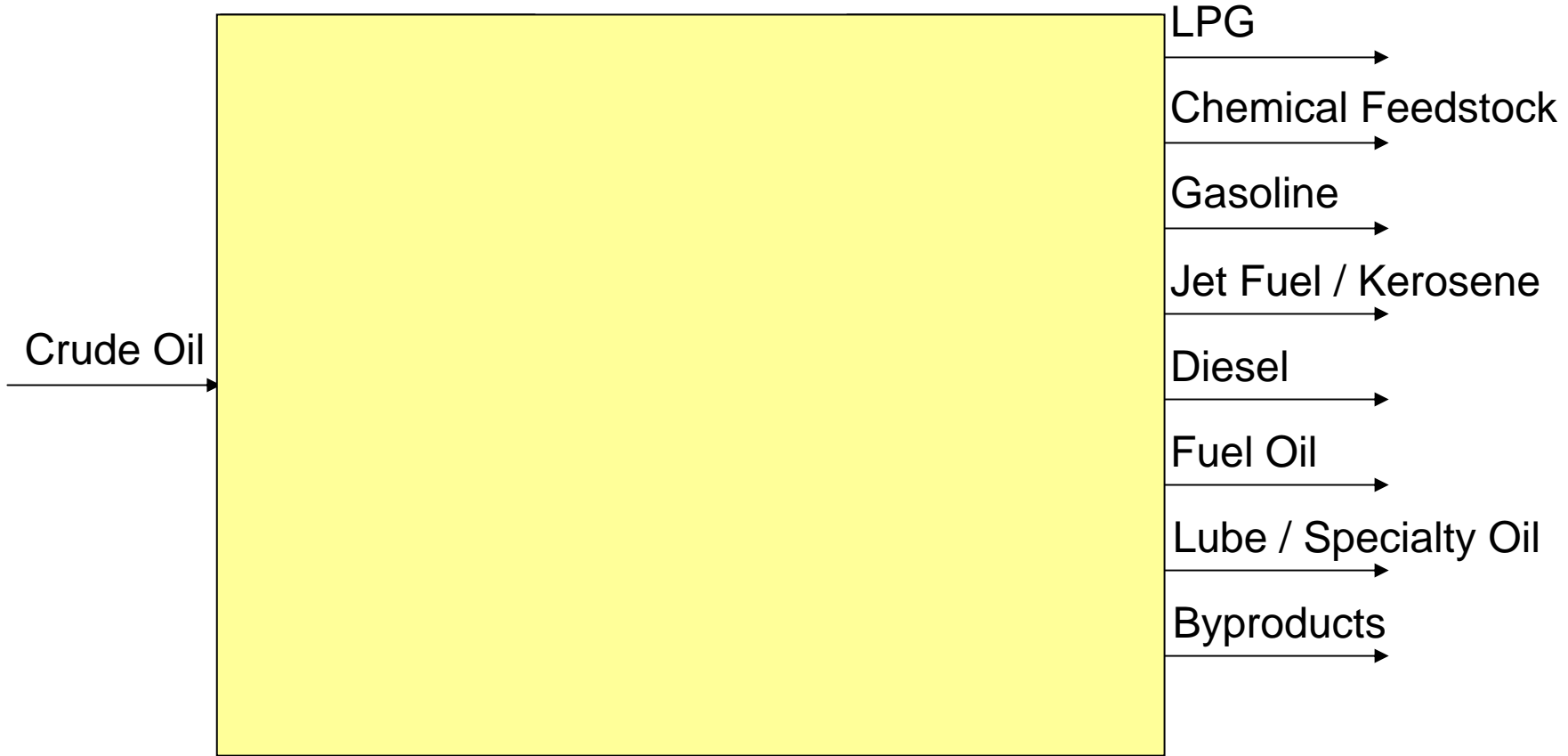

# Refinery Units and Streams

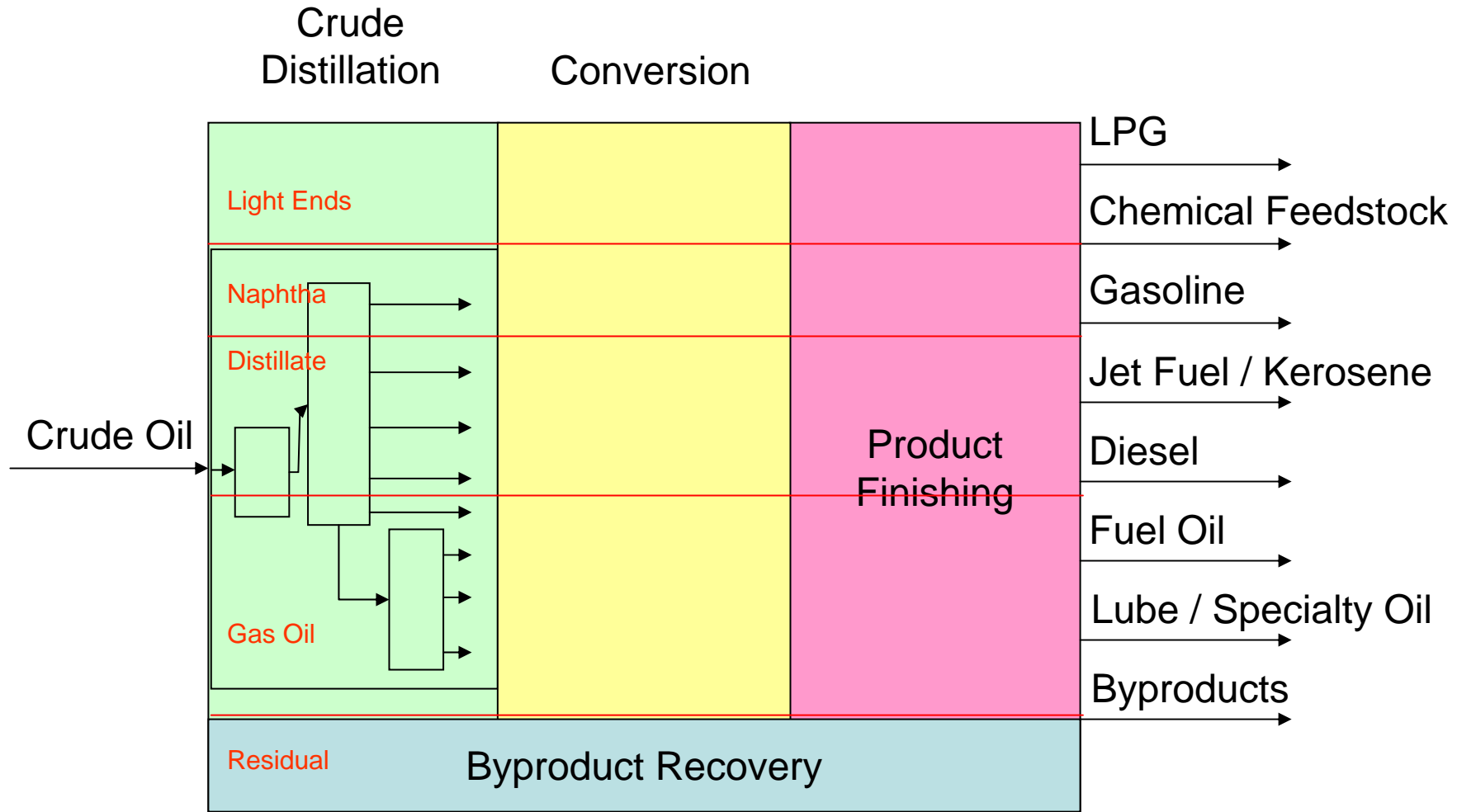

# Refinery Units and Streams

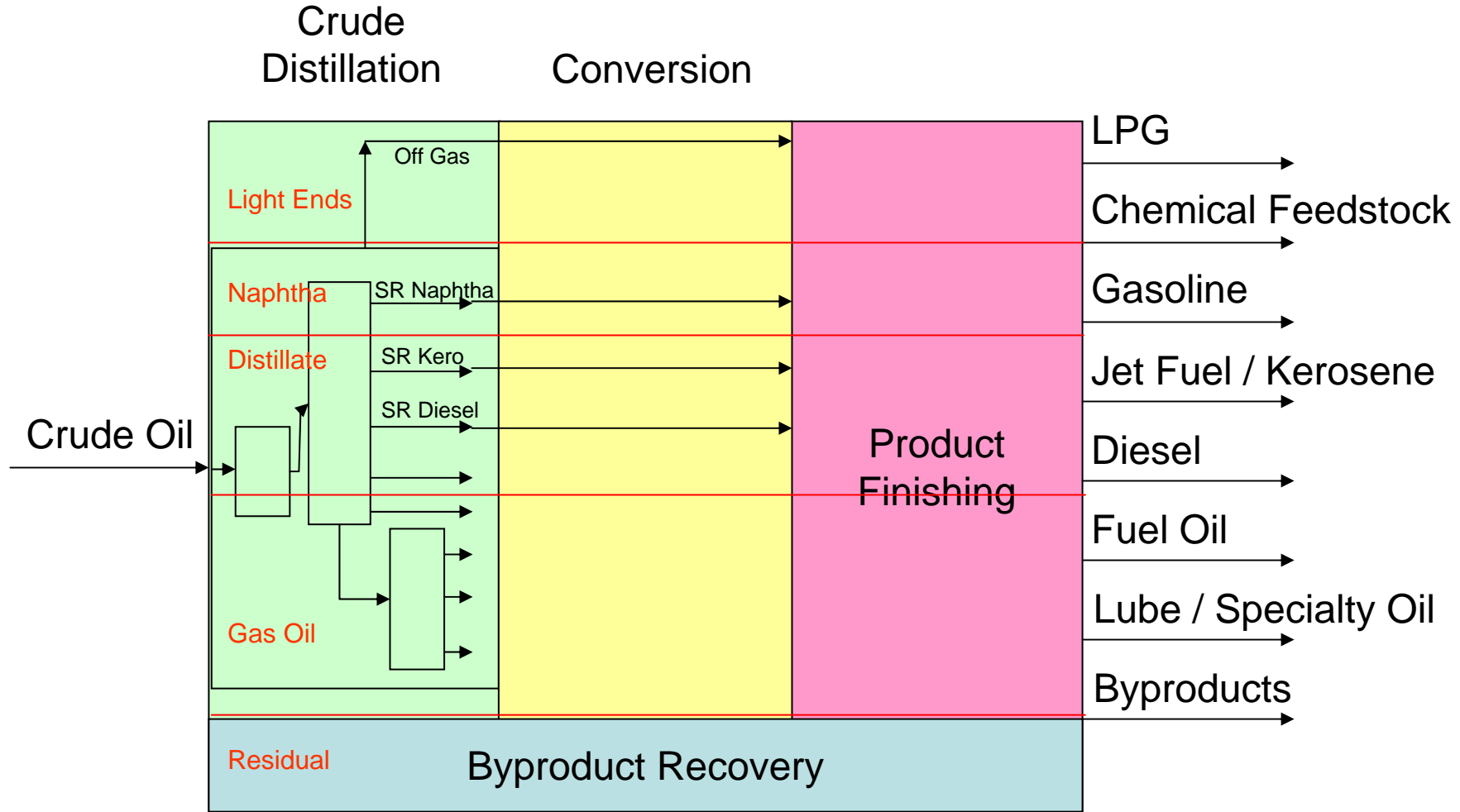

# Refinery Units and Streams

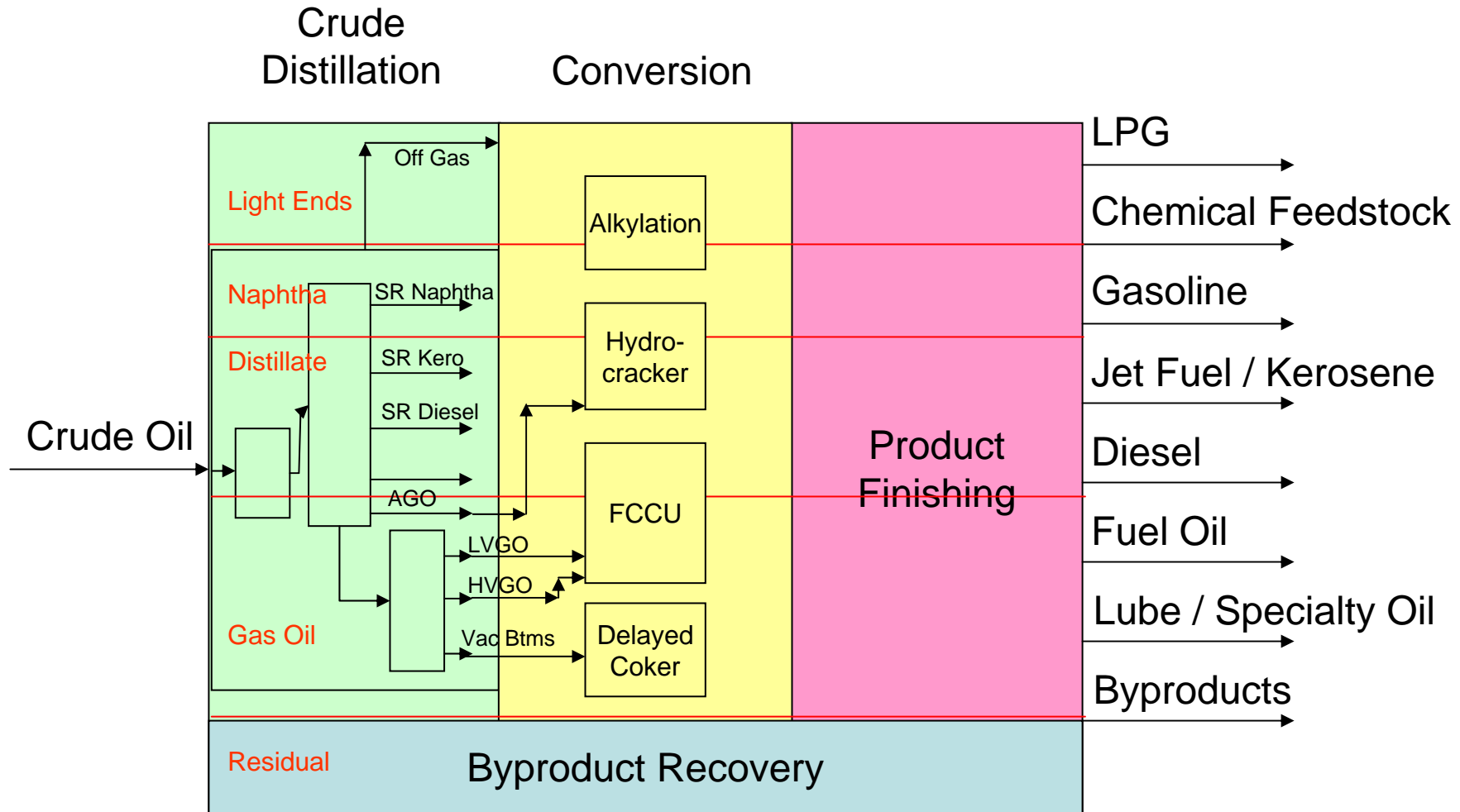

# Refinery Units and Streams

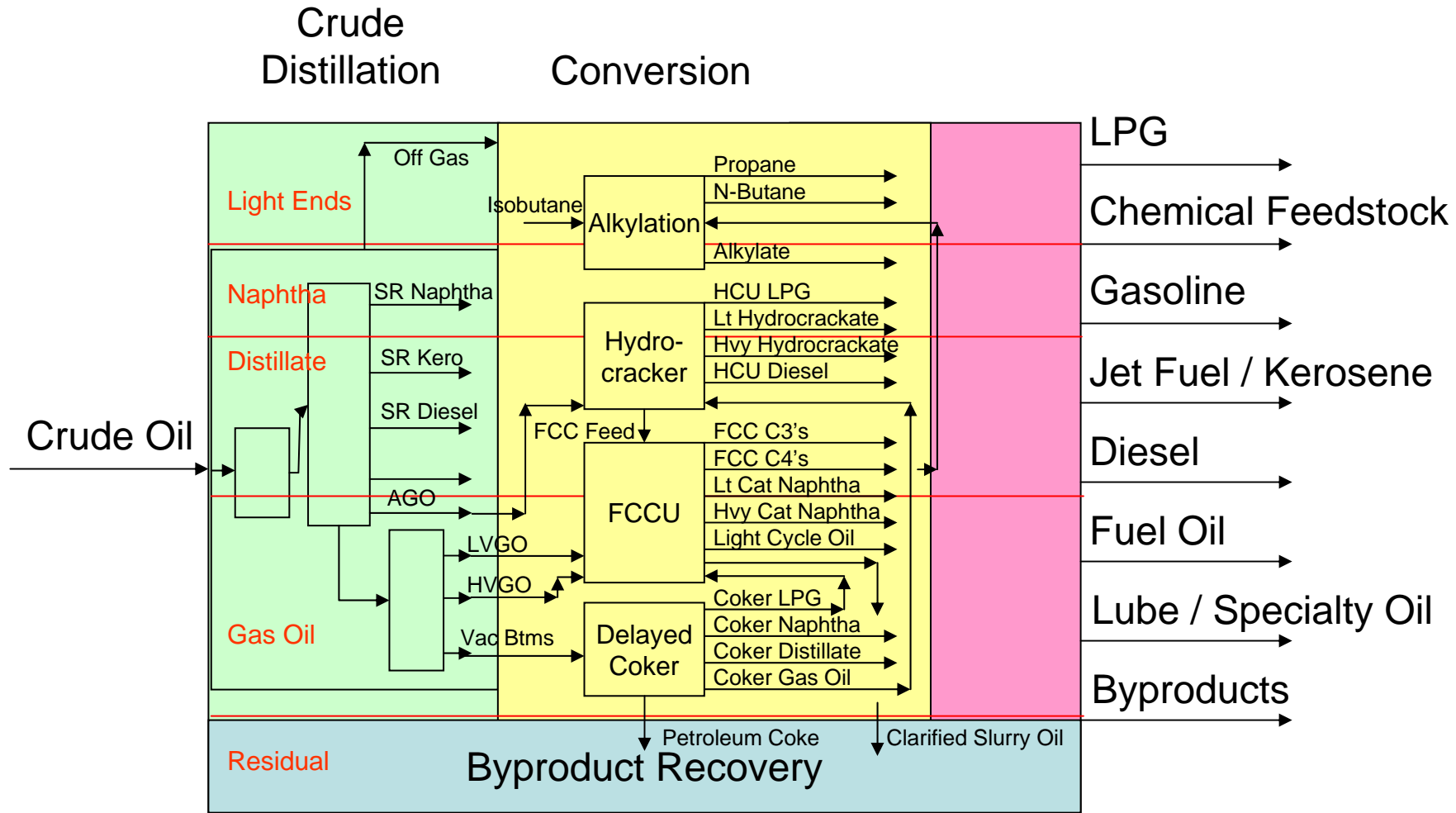

# Refinery Units and Streams

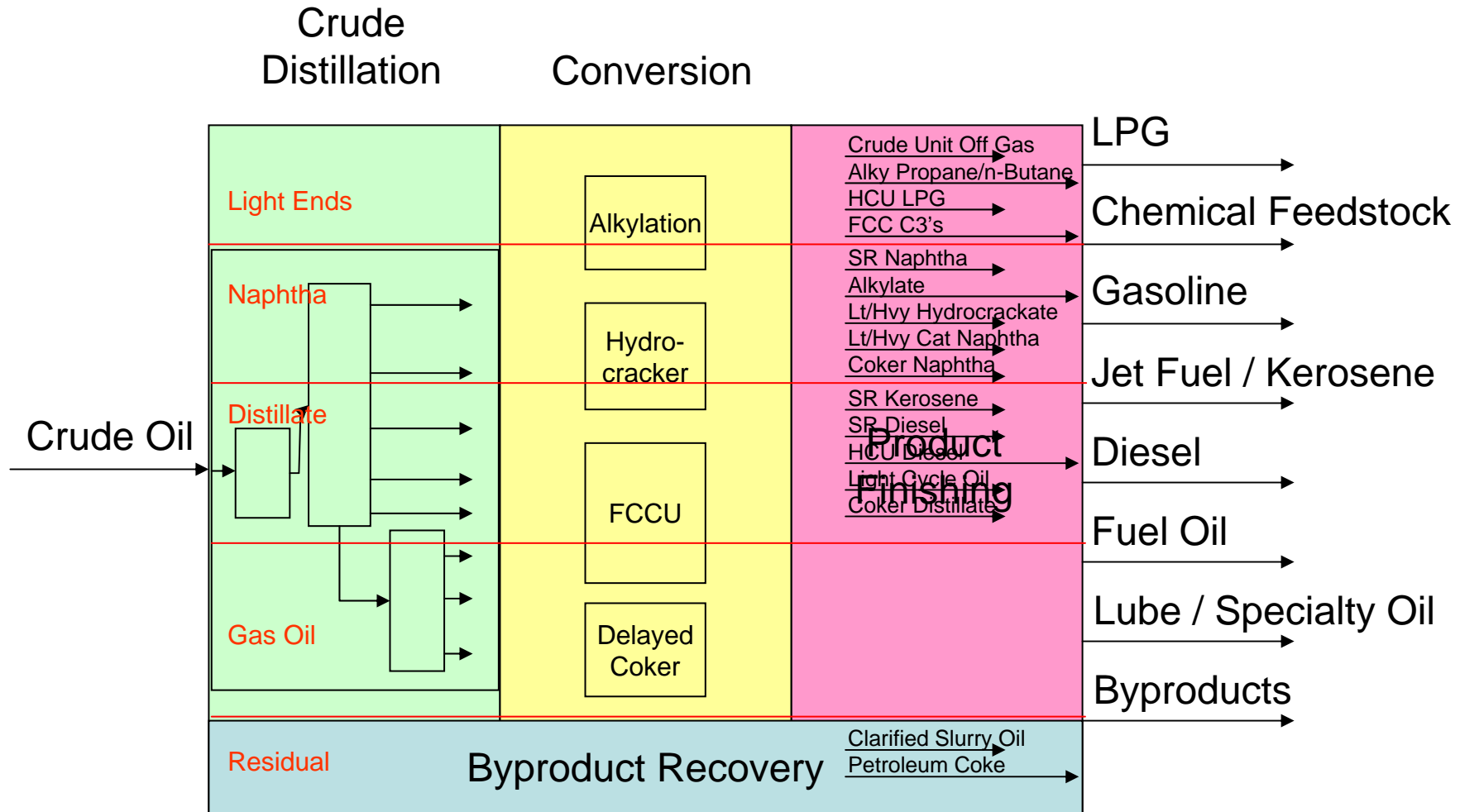

# Refinery Units and Streams

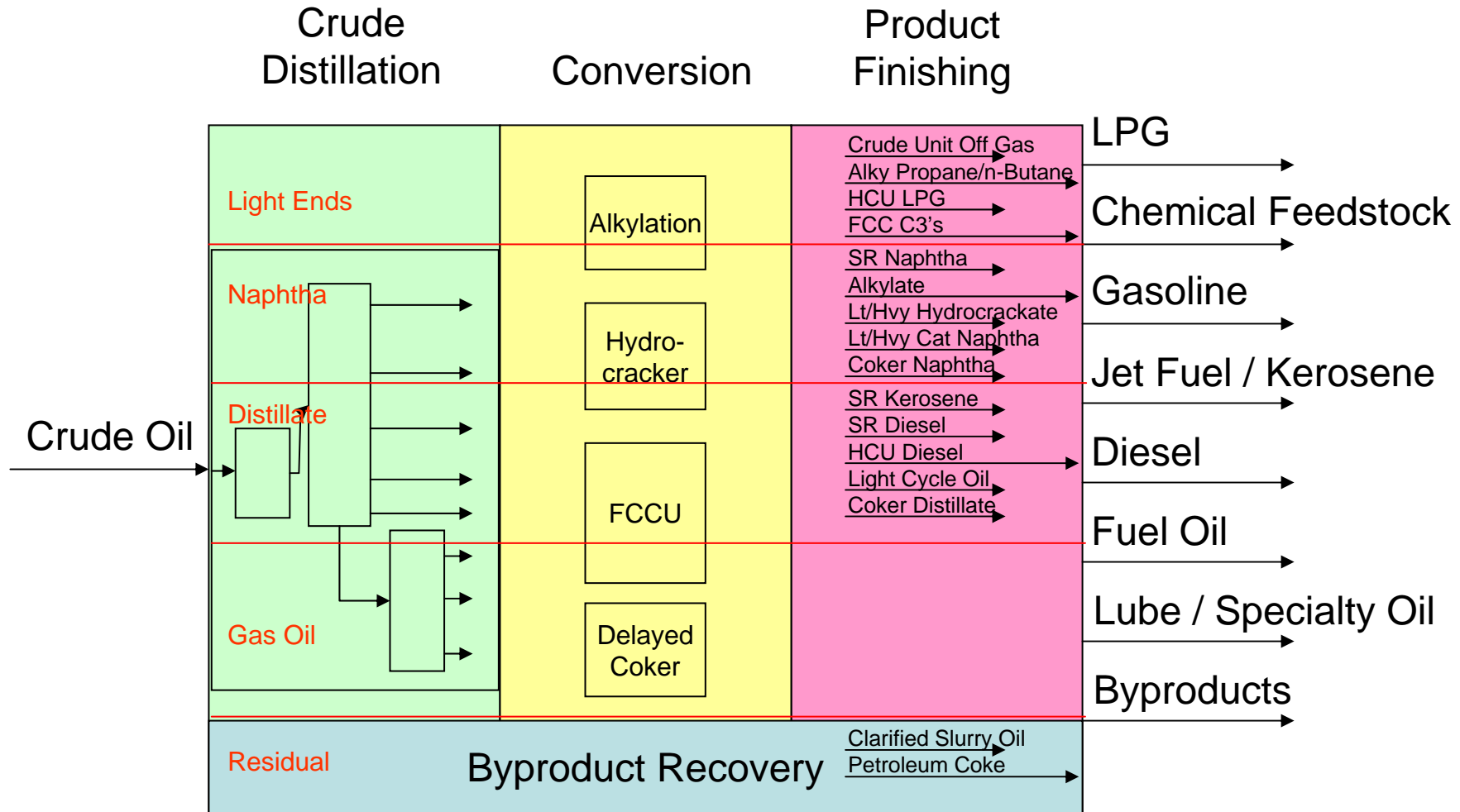

# Refinery Units and Streams

Jacobs Process PIT

Questions and Comments?